

SPECIAL DEMANDS ON PROCESS ENERGY SOURCES FOR HYBRID MACHINING ED/EC PROCESSES

Hans-Peter SCHULZE¹, Anjali DE SILVA², Kapila MEDILIYEGEDARA³, Joe A. MCGEOUGH⁴, Günter WOLLENBERG⁵

ABSTRACT

Hybrid machining processes are characterized by essentially changing load conditions. When we consider EDM and ECM, the spark erosion represents a non-linear load condition, where considerable changes of the gap conditions occur. The EC process is in good approximation a linear process. In time-parallel combined machining, the process energy source must be designed to adapt to the required gap conditions through the characteristic of the energy source.

Hybrid processing with such an energy source demands also new solutions for the process control. At the example of the hole sinking with a combined method of EDM and ECM, specific solutions and the operation principle of the novel energy source are shown.

KEYWORDS Electrical Discharge Machining, Electrochemical Machining, Hybrid Machining, Process Energy Source

1. MOTIVATION

Individual machining processes are characterized by desired advantages and disadvantages. The demand on the hybrid machining processes consists in eliminating these disadvantages and/or reduces them. The unconventional machining processes spark erosion and electrochemical processing; represent very different load conditions for the process energy source.

In this way, we have two cases of condition, the limiting values of current and voltage, and the linearity and/or the nonlinearity of the load parameters. A further demand on the process energy source is to arrange the adjustable operating ranges with a high flexibility. For the different applications, very different control systems of the energy source result in the specific one. But also the process control system for the stabilization of the machining process can change fundamentally.

The objective of the studies is to define the specific requirements of the individual processes. Thus, the demands on the hybrid process can be formulated more clearly and easily implemented. The two selected machining processes have strong requirements on the energy source so that also the most important characteristics must be considered.

2. INFLUENCES OF THE PARTIAL PROCESS

2.1 Electrical Discharge Machining

The spark erosion represents a non-linear load condition which is identified through

- the electrical insulation condition of the dielectric,
- the discharge conditions for the electrodes arrangement,
- the thermal impact of the spark (plasma channel and gas bubble),
- the deionisation of the working gap after the spark discharge.

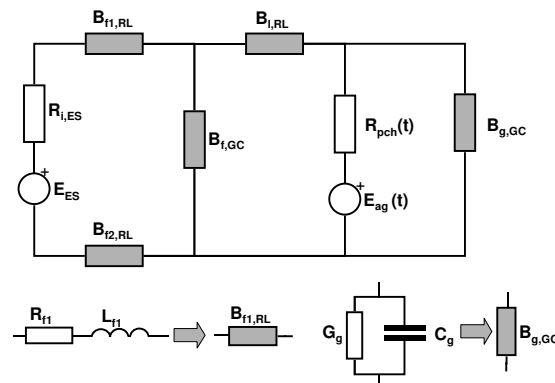

Fig. 1 Equivalent circuit diagram for feeder, loop and gap (EDM)

In Fig. 1 an equivalent circuit of the feeder, the loop and the working gap is represented. The connection line to the energy source can be described up to the loop formation at the working gap by the components $B_{f1,RL}$ and $B_{f2,RL}$ (resistance and inductance of the feeder) and capacity $B_{f,GC}$ (conductance of the feeder). The loop to the contacts of the electrodes is featured by $B_{l,RL}$ [1]. The working gap is defined by the electrode arrangement and the dielectric working fluid, that is described by $B_{g,GC}$, the parallel connection of $C_{g,kl}$ and $G_{g,kl}$ (see Fig.2). One of these nm-parallel $C_{g,kl}/G_{g,kl}$ arrangements is replaced in the branch $R_{pch}(t)$ and the counter voltage $E_{ag}(t)$ during the erosion phase.

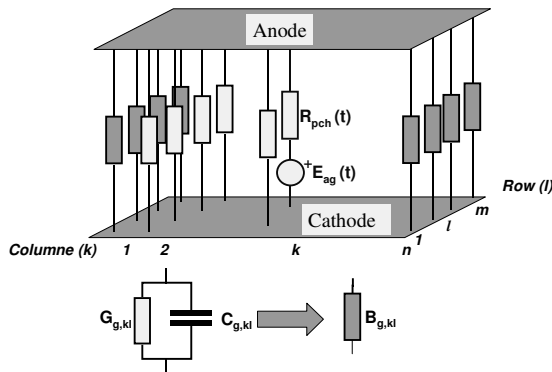

Fig. 2 Equivalent circuit elements in the EDM working gap

This equivalent circuit diagram can be used for all spark-eroding arrangements. The differences consist only in the range of values of the capacities, the inductances and the resistances. The feeder parameters must be considered, because they differ very strongly for the different techniques, as sinking erosion, wire erosion and microerosion. The nonlinearity of the load is given by the transition of the high-impedance dielectric into the low-impedance state of the plasma channel and the recovery of this component again onto the insulation level of the dielectric fluid. In Fig. 3 the temporal dependence of the equivalent parameters for the spark-eroding working gap is represented. The electrode arrangement and gap size play a determining role for the dielectric working fluid. While eroding we distinguish particularly the hydrocarbons (n-dodecane) with an almost negligibly small electric conductance and the de-ionized water with a higher electric conduc-

tance. In Fig. 4 a comparison of the admittance spectra of n-dodecane and de-ionized water is carried out for a working gap of 20 μm , a frequency range of 10 Hz to 10 MHz and a plate-plate arrangement [2].

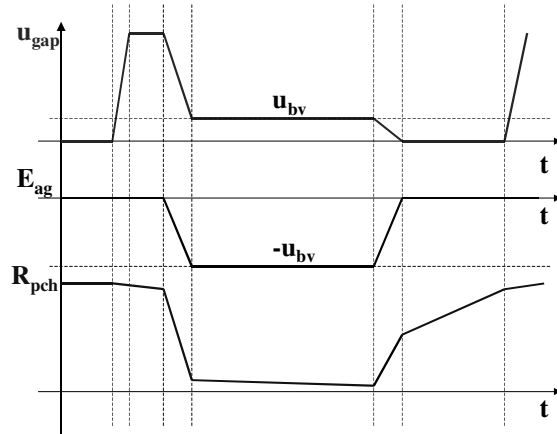

Fig. 3 Equivalent parameters for one spark discharge (EDM)

u_{gap} – gap voltage, u_{bv} – burning voltage, E_{ag} – voltage source in the equivalent circuit, R_{pch} – Resistance of the plasma channel

The results for the hydrocarbon show for the entire operating range that for the dielectric model only a capacity must be considered. Whereas, if de-ionized water is used as dielectric fluid then the equivalent branch for the model represented in Fig. 2 includes capacity and conductance.

These conditions are treated in extension in the paragraph for the hybrid processes and used as an active process phase.

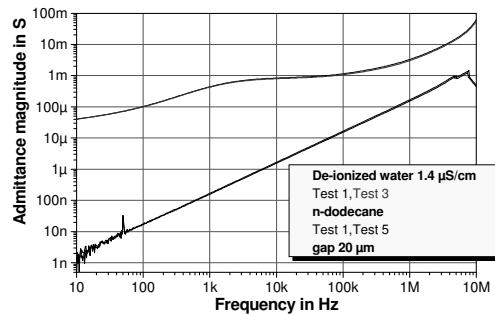

Fig. 4. Admittance spectrum for different working fluids (EDM)

2.2 Electrochemical Machining

The electrochemical machining uses an electrolytic liquid as a working fluid which, in first approximation, presents a linear gap characteristic. When a pulsating voltage is applied to the EC working gap, two processes may influence the linear gap characteristic.

Firstly, the current density that through the electrochemical cell feeds a heating of the working fluid. This heating leads to a change of the electric conductivity and thus to the anodic removal. Figure 5 shows, that in the equivalent circuit, the electrolyte can be modelled by means of a series circuit of resistance R_g and inductance L_g (see Fig. 6). For the transition phase of electrolyte in dielectric this equivalent circuit diagram must be complemented by a supplementary parallel capacity C_g . This equivalent circuit diagram has also validity for working frequencies higher than 200 kHz.

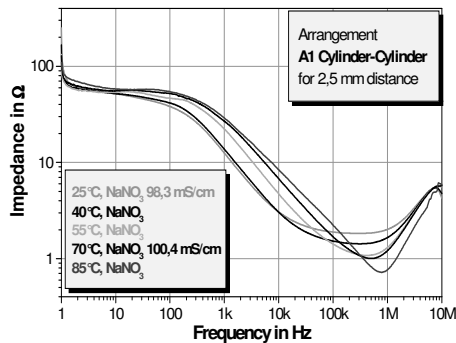

Fig. 5 Impedance spectrum for the electrolyte NaNO_3 for different temperatures (ECM)

Secondly, the anodic dissolution at the work-piece electrode depends on the effective current density that changes the voltage across the working gap.

The gap is influenced primarily by temperature, gap pollution, flow profile. In the equivalent circuit diagram of figure 6 this effect becomes noticeable in the change of the increase of the gap parameters. Because the removal for all components B_g occurs, the current density increases if some components $B_{p,kl}$ passivate (Fig. 7).

The electrochemical machining can come through the jumping change of the gap resis-

tance (high-impedance passive layer) to the stagnancy.

The feeder in figure 6 is during the hybrid process the same as for the erosive process.

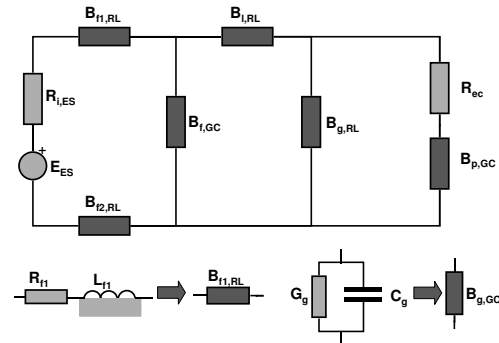

Fig. 6 Equivalent circuit diagram for feeder and working gap (ECM)

The passivation layer can be lift only by means of:

- bipolar pulses,
- pulsed machining with high current density,
- chemical solution of the passivated layer.

In figure 6 only a component is passivated, which is not the typical case. Dependently on the passivation layer time (too small current density) the complete processing face is passivated in a very short time (ns- μ s) [5], that is the series circuit $B_{g,RL}$ is replaced completely by the series circuit R_{ec} and $B_{p,GC}$. This equivalent circuit shows too that a small non-passivated face causes an electrochemical removal.

Local constructed passivated layers lead to a worse processing accuracy.

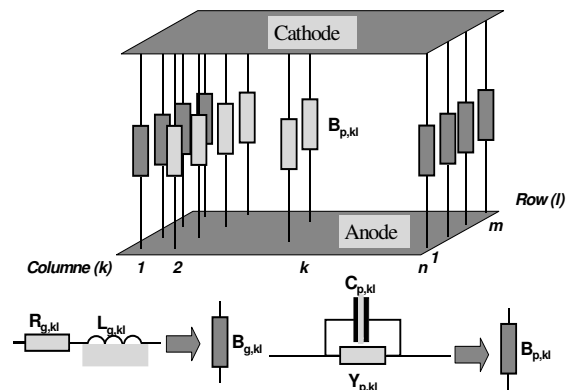

Fig. 7 Equivalent circuit elements for the EC-gap and passivated layer (local)

The electrochemical processing can occur only as a hybrid machining part if a sufficient electric conductivity of the working gap is guaranteed. This can happen in the entire working gap volume (electrolytes) or can be produced by an assisting technique (laser, electrolyte) locally [3], [4]. Also electrochemical processes can progress if the degree of pollution of a dielectric increases so strongly that a sufficient current can pour through the working gap.

3. LOAD CONDITIONS OF HYBRID PROCESS

In the first place, the hybrid load conditions are determined by the classification of the subprocesses as main removal processes or as assisting processes (Fig. 8) [3]. This decision is exclusively dependent on the electrical conductivity of the working fluid and the passivating mechanisms.

In this report two typical cases are supposed to be considered.

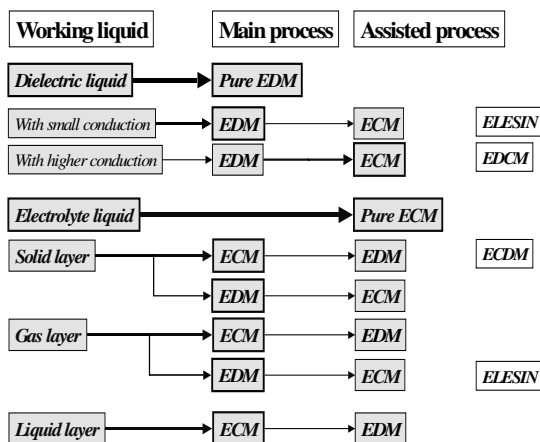

Fig. 8. Hybrid processes with EDM and ECM [3]

EDM as assisting process

The spark erosion occurs only as an assisting process if the processing face is completely passivated. Because the passive layer constitutes only one part of the gap width, the electrically conductive remaining gap can be complemented by the resistance R_{ec} . This part corresponds to an enlargement of the real part of the feeder $B_{i, RL}$.

The gap voltage is connected almost completely to the passive layer (nm to μm -range), this breakdown can occur at smaller ignition voltages. The passive layer reduces simultaneously the working gap and the flushing effectivity. The precision of the spark-eroding removal becomes more precise because virtually only the passive layer is considered as a breakdown gap. The spark erosion is expected of, that a sufficient surface segment is activated again for the EC removal. This condition means if the eroded face is too small then it comes deeper EC removal because of the very high current density.

Which work result is reached depends on the type of the passivating layer. Fixed passive layers can be destroyed electrically only by bipolar pulses, very high current densities or high field strengths. The load conditions for the hybrid ED process are strongly determined through the uniform solid layer formation.

In the case of gaseous passive layers which are very movable also the gap flushing can lead to the elimination of the layer. Thereby, very unstable load conditions can be found in the working gap. At small gap widths the load condition can be stabilized by the strong gas bubble formation again, that is, under specific boundary conditions a gaseous discharge occurs in the working gap.

Through the flushing in the lateral gap the electric conductivity can become locally very high, which causes a great tapering during the processing.

The consequences for avoiding this processing inaccuracy are for the combined machining:

- the changed electrolytes (working fluid),
- the EC-process with a shorter pulse duration and higher current densities (energy source),
- the specific flushing that in the lateral gap the electric conductivity does not in addition increase.

The process also can become problematically, when a passivation layer occurs at both electrodes. Then the breakdown conditions are complicated because the EC-process can occur only if both passive layers are destroyed. The gap voltage can in these situations become so large, that:

- the heating of the electrolyte becomes critically,
- undefined wear at the tool occurs,

- the gap voltage to the breakdowns is too high and in consequence the mean working gap accepts unwanted values.

Then the gap voltages to be analyzed can not be assigned unambiguously, what means that is the algorithms and models of the process controls are to be determined again.

ECM as assisting process

In this case we have to do it with complete time-parallel combining methods. The electrochemical processing occurs parallel to the spark erosion, as a process for the smoothing of the eroded surface. This process can be shown best at the u - i -characteristic of a pulsed current supply with adjustable limited voltage u_{lim} .

Figure 9 shows the u - i characteristic of the developed process energy source for the precise hole sinking in hard alloys [3].

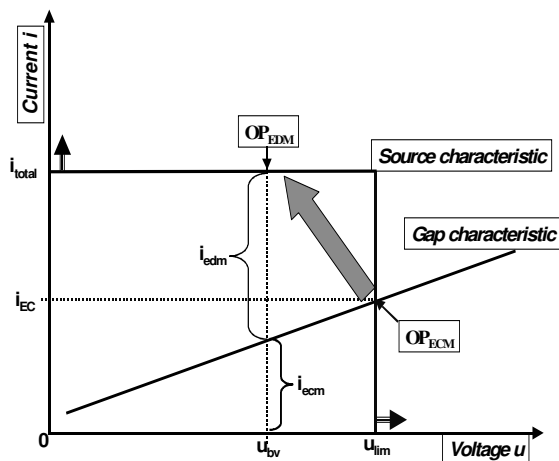

Fig. 9. u - i -characteristic for a hybrid process energy source [3]

The gap characteristic is represented by the characteristic resistance of the working fluid. The process energy source shows up to the limited voltage u_{lim} an ideal current characteristic whose current amplitude i_{total} is adjustable according to the technological problem definition. After the limited voltage u_{lim} is reached, the current characteristic changes into an ideal voltage characteristic. The limited voltage is adjustable and given by the electric conductivity of the working fluid.

The classical example of the "unintentional" combined machining is the wire erosion with de-ionized water. According to Fig. 8 this "hy-

brid" process must be considered as if the spark erosion is the main process and the EC process the assisting one running in parallel. According to Fig. 9 the current i_{edm} will flow through the discharge channel (Fig. 2) and through the remaining gap an electrochemical removal with the current i_{ecm} occurs. If the parallel electrochemical removal is supposed to be minimized, the electric conductivity of the electrolyte must be reduced so that the current i_{ecm} does not reach any effective current density (with reference to entire electrode surface).

The desired combined process demands, that both processes become effective and insert their advantages in the hybrid process.

The first question is, which working fluids can be used. For a passivating electrolyte must the currents i_{ecm} and i_{ECM} are outside of the range of passivating current densities. This problem can be eliminated through the selection of the working current i_{total} and the limited voltage u_{lim} .

The second question concerns the limited voltage of the energy source. This can be adjusted that the ECM occurs only in the range of the voltage characteristic. The consequence of this setting is that the EC-removal with variable current amplitudes occurs. For larger working gap (R_g rises) the working current i_{OPECM} becomes smaller, that is the hazard because the process truncates or a passivation layer occurs increases. With stronger pollution (R_g falls) the current i_{OPECM} becomes greater, that is the removal increases.

Through the adaptability of the u - i -characteristic it is possible that the EC-machining can occur with a maximum current i_{total} . It is required that the EC machining with constant gap current occurs, then the limited voltage must be increased. At considerably greater gap voltages the probability of electrical breakdowns and overheating of the working fluid becomes larger.

The presented process energy source shows which potential of the hybrid processing is possible and which great flexibility of the process parameters must be implemented.

4. CONCLUSIONS

The specific conditions onto the process energy sources for combined machining with the unconventional techniques of EDM and

ECM are characterized by the load conditions at the working gap.

The EC-process can be regarded as a linear approximation. Through the formation of passive layers also this process becomes non-linear.

The spark erosion can be considered as essentially non-linear through the electrical breakdown fundamentally.

With the gap-models for EDM and ECM the specific requirements can be analyzed for the combining methods in advance. For the process energy sources a very precise parameter definition can be indicated for the pulse parameters.

In this way the exploration of the fundamental processes can be arranged at the combining methods very effectively.

In the industrial field, the process energy sources can be adapted to the particular application, which makes it more profitable.

REFERENCES

- [1] Günter WOLLENBERG, Hans-Peter SCHULZE, Matthias TIMM, Thomas PAPE, *Simulation of EDM Installations*, Proceedings International Symposium for Electromachining XI, April 17-21, 1995, EPFL, Lausanne, Switzerland, pp. 153-162.
- [2] Hans-Peter SCHULZE, Günter WOLLENBERG, Stefan MATZEN, *Analysis of the gap conditions of the spark erosion for different working liquids and electrode arrangements*, (accepted paper) The 19th International Conference CAPE2005 Computer Aided Production Engineering, 21-24 November – Melbourne Australia.
- [3] Hans-Peter SCHULZE, Markus LÄUTER, Günter WOLLENBERG, Maria ZYBURA-SKRABALAK, Anjali K. De SILVA, *Process energy Sources for the electrochemical process and hybrid Machining with ECM*, Proceedings of the 3rd International Conference on Machining and Measurement of Sculptured Surfaces, Krakow, Poland 24-26 September 2003, pp. 367-378
- [4] K P RAJURKAR, D. ZHU, J A MCGEOUGH, J KOZAK, A K DESILVA, *New Developments in Electro-Chemical Machining*, Annals of the CIRP Vol. 48/2/1999, pp. 1-13.
- [5] M S SMIRNOV, A N ZAITSEV, I L AGAFONOV, S V, BEZRUKOV, A L BELOGORSKY, V P ZHITNIKOV, *Electrochemical dimensional machining by microsecond duration current pulses*, Proceedings of the 13th International Symposium for Electromachining ISEM XIII (Vol. 1), May 9th – 11th, 2001 Bilbao, SPAIN, pp. 231-248

AUTHORS

¹PhD., Dipl.-Phys. Hans-Peter Schulze, Otto-von-Guericke-University Magdeburg, IGET, Germany, email: hans-peter.schulze@et.uni-magdeburg.de, phone: ++49-391-67-12944

²PhD. Anjali K. De Silva, Glasgow Caledonian University, UK, Scotland. email: A.DeSilva@gcal.ac.uk

³MSc T.Kapila K.R. Mediliyegedara, Glasgow Caledonian University UK, Scotland.

⁴Prof. PhD. Joe A. McGeough, The University of Edinburgh, UK, Scotland, email: j.a.mcgeough@ed.ac.uk.

⁵Prof. PhD. Günter Wollenberg, Otto-von-Guericke-University Magdeburg, IGET, email: wollenberg@et.uni-magdeburg.de