

## STEEL STRIP EMPLOYED AS TRANSFER OBJECT TO CUT OFF ALLOY STEEL USING CONTACT BREAKING ELECTRICAL EROSION

Țițu Mihail Aurel<sup>1</sup>, Bucur Viorel<sup>2</sup>

<sup>1</sup>"Lucian Blaga" University of Sibiu, titu.mihail@gmail.com

<sup>2</sup>"Lucian Blaga" University of Sibiu, bucur\_ani@yahoo.com

**ABSTRACT:** The authors' goal is to present some of the results of the undertaken research, regarding the alloy steel machining technology, using the steel strip as transfer object for cutting off. The arguments concerning the opportunity to employ steel strip as a transfer object, the calculi on sizing it and the surfaces that are almost in contact, the joint methods for steel strip as well as the materials used for this purpose are highlighted on this paper.

**KEY WORDS:** contact breaking electrical erosion, nonconventional technologies, experimental research, physical mechanism of contact breaking electrical erosion.

### 1. INTRODUCTION

*Opportunity of employing the steel strip as transfer object*

The researches undertaken in this field related to the possibilities of employing certain transfer objects specific to certain technological procedures (like cutting off) for rolled products of alloy steel, all these have highlighted a series of specific aspects.

Thus, regarding the cutting off using CBEE, the most used transfer object (T.O.) is the steel disk, but as for the opportunity of its employment, the experts have underlined certain issues and the most important are as follows [2]:

- high electrical energy consumption, generated as a result an "arc fault" between the lateral surfaces of the steel disk and processed object (P.O.);
- productivity decline in the same time with the enhancement of P.O. section;
- limited use of steel disk in case of enhancement of P.O. section, determined by the ratio  $ROT \leq ROP$ .
- *Calculating the lateral contact surfaces between T.O. and P.O.*
- Employing the steel strip as a Transfer object (T.O.) can lead to a series of advantages and the most significant ones are the following [4]:
- lateral contact surfaces are considered to be more reduced and thus the appearance of an "arc fault" is insignificant according to figure 1;
- possible employment of certain technological parameters cu smaller values and implying reduced consumptions of electrical energy;

- better stability of working process and smaller values of working flow.

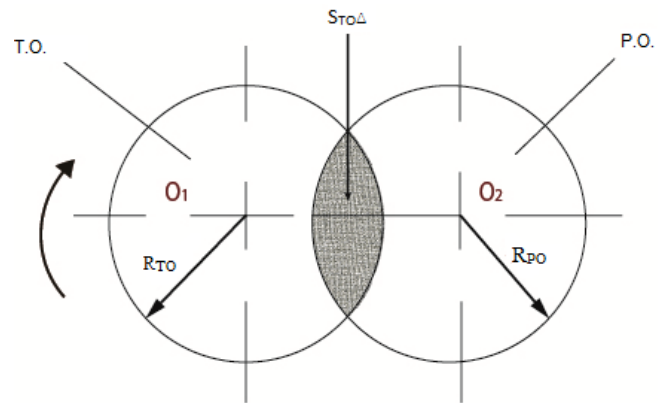

**Figure 1.** Contact surfaces between T.O. and P.O. - steel disk (when T.O. is a steel disk,  $R_{TO} > R_{PO}$ ;) )

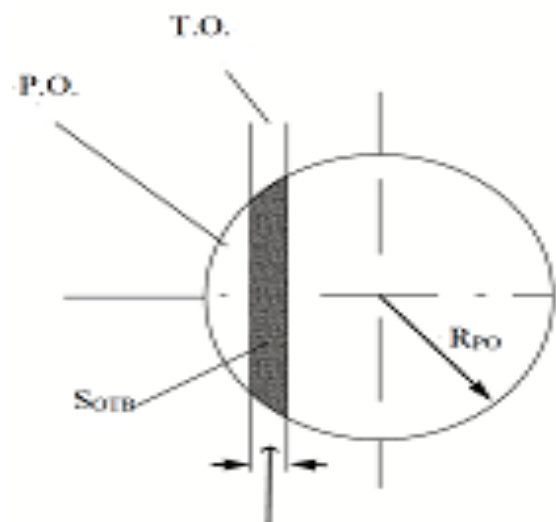

**Figure 2.** Contact surfaces between T.O. and P.O. - steel strip (when T.O. is a steel strip)

Note: The hachured area shows the arc fault discharge ( $S_{OT\Delta} > S_{OTB}$ ), in case of cutting a cylindrical bar.

And, related to objects with prismatic section, the arc fault area is wider when employing steel disk as transfer object, according to figure 3.

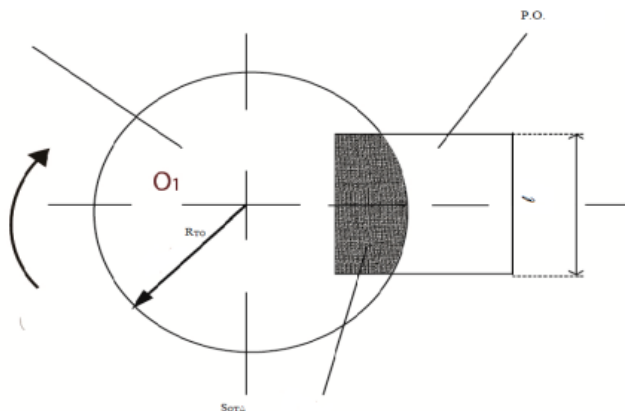

**Figure 3.** Contact surfaces between T.O. and P.O. for prismatic objects - steel disk (steel disk is used as T.O)

According to the analysis of lateral contact surfaces of steel disk and steel strip, the following conclusion can be reached: steel strip employment as T.O. has a series of advantages, because the lateral contact surfaces (where an arc fault is formed) are considerable smaller, fact underlined by the data in the table 1.

**Table 1.** Analysis of lateral contact surfaces of steel disk and steel strip

No.	P.O. dimensions (mm) D	Steel disk		Steel strip		Lateral contact surface ratio [%]
		Disk Ray [mm]	Lateral contact surface STOD [mm <sup>2</sup> ]	Width [mm]b	Lateral contact surface STOB [mm <sup>2</sup> ]	
0	1	2	3	4	5	6
1	200	300	9810.6	30	5862	59.7
2	400	500	39200	30	11391	31.0

*Calculating the surfaces almost in contact between T.O. and P.O.*

Using same dimensions for the processed object (P.O.) and transfer object (T.O.), steel disk and steel

strip, for the specific geometrical parameters in table 2, smaller values were reached both for contact length and contact area, with over 50% in case of steel strip employment.

**Table 2.** Geometrical parameters

No.	P.O. dimensions (mm) D	T.O. dimensions				Dimensions					
		Steel disk		Steel strip		Steel disk			Steel strip		
		R[mm]	a[mm]	b[mm]	a1[mm]	$\alpha_0$	cl [mm]	Ca[mm <sup>2</sup> ]	$\alpha_0$	cl [mm]	Ca[mm <sup>2</sup> ]
0	1	2	3	4	5	6	7	8	9	10	11
1	200	300	5	30	1	45	235.5	1177.5	0	200	200
2	400	500	8	30	1	50	436.33	3490.66	0	400	400

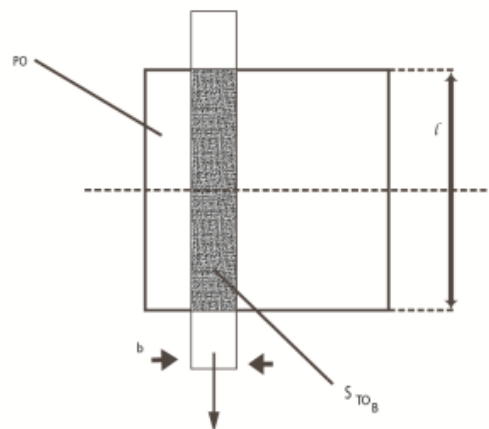

**Figure 4.** Contact surfaces between T.O. and P.O. for prismatic objects - steel strip (when steel strip is employed as T.O.)

Note: The hachured area shows arc fault discharge ( $SOT\Delta > SOTB$ ) in case of cutting a prismatic section.

The experimental reached values enhance that fact that using steel strip as T.O. leads to smaller values of working flow reported to the contact length and area (cl and Ca), thus ensuring a great stability of machining process in a smaller thermal – influenced area (t.i.a.) and implicitly more reduces power losses.

## 2. MATERIAL RECOMMENDED TO MAKE T.O. – STEEL STRIP

Among the goals borne in mind during researches, an important places was reserved for the problem solving and clarifying on knowing the optimum material that could have ensured the strip production in terms of its behavior during technological process and economy.

The following main machining conditions were met:

- Ensuring a high durability of T.O.;
- Safety when working;
- Uniformity of length and depth of T.O.
- In terms of main economic conditions borne in mind, the following must be mentioned:
- Low cost of material;
- Minimum cost for preparing the process itself of building the T.O.

Note: The theoretical and experimental researches undertaken were based on a determining influence of “T.O. – P.O. pair optimization”, in order to ensure stability to the working process and high productivity.

### *Materials compatible to create a steel strip*

Among the factors taken into account when choosing the materials to create T.O., the following have to be reminded:

- technological conditions;
- adopted constructive conception;
- working conditions;
- technical capability of material and its physical and mechanical properties.

It needs to be bear in mind the fact that during the cutting off process, the steel strip is subject to mechanical stress and efforts when fatigue occurs; thus it is enforced the fact that employed materials have to accomplish a several requests, like:

- resistance (to dynamical pressure, to fatigue), flexibility, durability;
- durability when functioning, to multiple cycles;
- possibilities to apply certain thermal treatments.

In order to create the T.O., “narrow cold-rolled carbon steel strips” were used, delivered in rollers,

its thickness being of 0.3-1.0 mm, and its width between 30-50mm.

These materials have their chemical composition thoroughly measured and controlled and the carbon content does not exceed 0.25%.

## 3. TRANSFER OBJECT DESIGN – STEEL STRIP

### *Manufacturing conditions*

The transfer object design implied clarification and solving of certain technological, working, and quality aspects imposed.

In this context, the steel strip is made as a closed frame, according to figure 5, the ends being joint, solid in case of welding, brazing or rolling.



**Figure 5.** Steel strip employed as T.O

The following were taken into account:

- Choosing type of T.O. and the most appropriate material for it;
- Determining the working dimensions of T.O. and setting out the main parameters (mechanical, electric, etc.);
- Identifying the technology for machining, employment, mending, and reemployment of T.O.;
- Calculating T.O. resistance to dynamic stress during working process.

One of the goals was for T.O. to meet in the same time a series of conditions (on technology, work, mount, employment, economy).

### *Steel strip end joint*

During the CBEE process, steel strip is permanently subject to several variable stresses.

The steel strip ends were butt-welded joint in a protective gas environment, horizontally, without machining the margins.

Samples were made that were subject to traction force, and highlighted the good quality of welded joint.

The working parameters used are shown in the following table.

**Table 3.** Working parameters

No.	Parameter	M.U.	Symbol	Working value	Remarks
0	1	2	3	4	5
1	Protective gas (Argon)	%	Ar	99.97	Purity
2	Welding current	A	IS	80-100	
3	Spring tension	V	UO	15	
4	Gas volume	l/min	QAr	5-7	
5	Welding rod diameter	Mm	Ø	1.2	

A steel strip with closed frame was obtained after butt-welded.

#### Technological conditions

The transfer object – steel strip – is made as a closed frame, using normal carbon steel of general use (OL-37, OI-52) as basic material.

The width of steel strip ( $b$ ) is determined by the width of working flywheels ( $B$ ) and the length ( $L$ ) according to the distance between the flywheels axis ( $A$ ) and their diameter ( $D1,2$ ), like in figure 6.

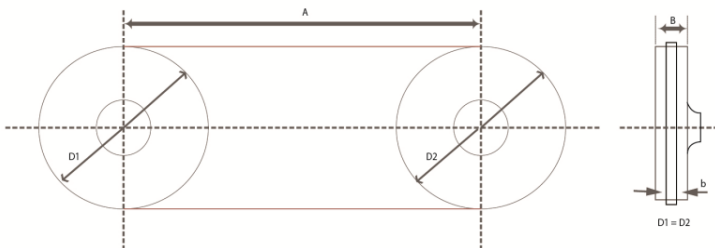

**Figure 6.** Steel strip on working flywheels.

The steel strip dimensions were established by taking into account:

- the constructive elements of steel strip (length, width, depth);
- the joint forms agreed on.

After applying traction and fatigue, the optimal methods of butt joint were reached, these being machined through CBEE.

The constructive and technological conception of steel strip (T.O.) executed by welded construction.

The constructive shape of transfer object made by butt-welded joint (figure 7) has to correspond to the changing stress to which is subject during CBEE machining (fatigue, stretch, bending, tension, etc.)

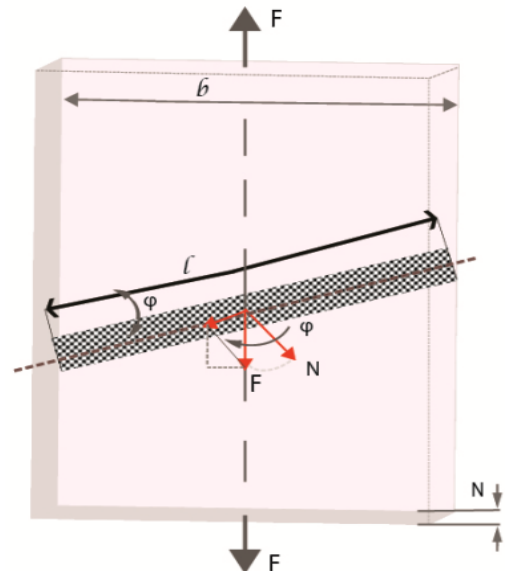

**Figure 7.** Traction force on T.O.

The significance of forces and elements:

- F- stretching force;
- N – traction force;
- T- shearing force;
- $\phi$  – welding angle;
- b- strip width;
- t – strip depth;
- l- welding corridor length.

A butt-welded, tilt joint and equally resistant was made for the values  $\Omega$  - 450 and  $f(\phi) = 1$ .

## 4. CONCLUSIONS

The research undergone brings to light the opportunity of employing the steel strip as a transfer object, in order to cut of alloy steel by using CBEE.

Those presented above reflect the low level of values of geometrical working dimension (table 2), in case of steel strip as T.O., comparing to the steel disk, and a lower consumption of electrical energy.

There has to be underlined also the cost of the T.O. manufacturing out of steel strip, comparing to the steel disk used to cut off the alloy steel using the classical chip removing.

## 5. REFERENCES

1. Bucur, V. *Aspecte tehnologice ale debitării prin E.E.R.C., cu O.T. – bandă metalică*, Referatul nr. 3, Universitatea Tehnică, Timișoara, (1996).
2. Bucur, V. *Contribuții la optimizarea tehnologiei de prelucrare dimensională prin eroziune electrică cu rupere de contact (EERC) cu obiect de transfer - bandă metalică*, Teza de doctorat, Sibiu, (1998).

3. Nanu, D, Bucur, V *Asupra oportunității utilizării benzii metalice ca obiect de transfer prin EERC.* TEHNOMUS VII, Suceava, vol. IV, (1993).
4. Nanu, D., Dușe, D.M. *Unele considerații teoretice privind prelucrarea prin E.E.R.C.,* C.N.T.N., vol. IV, Timișoara, (1983).
5. Sofonea, G., Nanu, D., Bucur, V. *Aspecte privind determinarea unor dimensiuni constructive funcționale la debitarea în E.E.R.C. cu bandă metalică,* Buletinul Științific al Universității Tehnice din Cluj Napoca, Seria Construcții de Mașini, Supliment, (1993).
6. Sofonea, G., Nanu, D., Bucur, V. *Determinarea dimensiunilor obiectului de transfer (O.T.) bandă metalică îngustă la debitarea prin E.E.R.C.,* C.N.T.N., vol. VI, Timișoara, (1993).
7. Sofonea, G., Nanu, D., Bucur, V. *Dimensionarea cilindrilor de antrenare a obiectului de transfer tip bandă îngustă și debitarea prin eroziune electrică cu rupere la contact,* C.N.T.N., vol. VI, Timișoara, (1993).
8. STAS 500/1, 2-90 Oțeluri carbon de uz general.
9. STAS 1945-90 Benzi înguste din oțel carbon, laminate la rece.