

# VIRTUAL HOME ALARM SYSTEM WITH NI MYDAQ AND LABVIEW

Bogdan Mihai

“Lucian Blaga” University of Sibiu, mihai.bogdan@ulbsibiu.ro

**ABSTRACT**– This paper present the use of data acquisition (DAQ) device and LabVIEW to implement a home alarme system. In order to achieve this aim, it requires a NI myDAQ device, an infrared motion sensor (PIR), a magnetic sensor with reed contact, a panic button, a speaker, electric conductors, a personal computer (PC) that will run your application in LabVIEW and a USB cable that connects between the DAQ and PC.NI myDAQ provides analog input (AI), analog output (AO), digital input and output (DIO), audio, power supplies, and digital multimeter (DMM) functions in a compact USB device.

**KEYWORDS:** NI myDAQ, LabVIEW, DAQ Assistant, Case structure.

## 1. THE REQUIRED APPLICATION COMPONENTS

### 1.1 The NI myDAQ

NI myDAQ is a low-cost data acquisition (DAQ) device that gives users the ability to measure and analyze live signals anywhere, anytime. NI myDAQ is compact and portable so users can extend hands-on learning outside of the lab environment using industry-standard tools and methods.

NI myDAQ includes 2 analog inputs and 2 analog outputs at 200 kS/s and 16 bits, allowing for applications such as sampling an audio signal; 8 digital inputs and output lines, providing power for simple circuits with +5, +15, and -15 volt power supplies; and a 60 V DMM to measure voltage, current, and resistance. Built on the same technology as industry-leading NI DAQ, these trusted tools give users experience they can use long into research and careers.

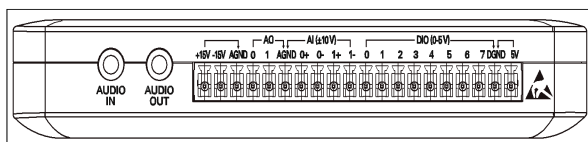

Figure 1. The NI-myDAQ

### 1.2 The PIR Motion Sensor

A PIR (Passive Infra-red) motion sensor is a low-cost device used to detect a change in its surroundings within a radius or 15 to 20 feet. This is used in many applications such as robotics and home security. These sensors are often found within buildings to turn on automatic lights as well. By harnessing the audio output jack on the NI myDAQ, we can output a blaring loud noise when motion is detected. The sensor communicates with a digital

signal, where a digital *high* (+5V) corresponds to motion detected. The sensor does require a DC power supply, which the myDAQ +15V rail can successfully provide, allowing for easy integration with the motion detector.

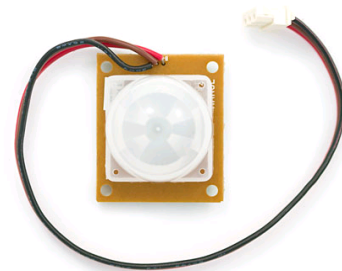

Figure 2. The PIR Motion Sensor

### 1.3 The magnetic sensor

The magnetic sensor is of the type SPNC SC516/WH, which contains a normally open (NO) reed contact. When the reed contact is in the magnetic field created by the permanent magnet, lines of the magnetic field is concentrated in ferromagnetic flexible plates and the plates are attracting and closed electric-contact.

The maximum working voltage is 50 Vdc and the maximum distance between sensor and magnet is 15 mm.

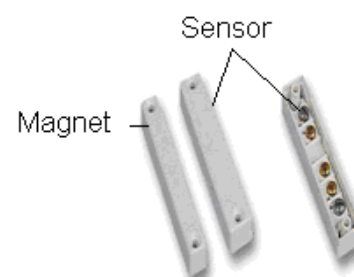

Figure 3. Magnetic sensor

## 1.4 The panic button

Panic button is without restraint, assembly, plastic housing white.



Figure 4. The panic button

and the current is 2mA. Because the minimum impedance that can be connected of DAQ device is  $8\Omega$ , the speaker chosen have  $32\Omega$  impedance.



Figure 5. The speaker

## 1.5 The speaker

The speaker chosen is of low power (0.25W), because the voltage of audio output is low ( $\pm 2V$ )

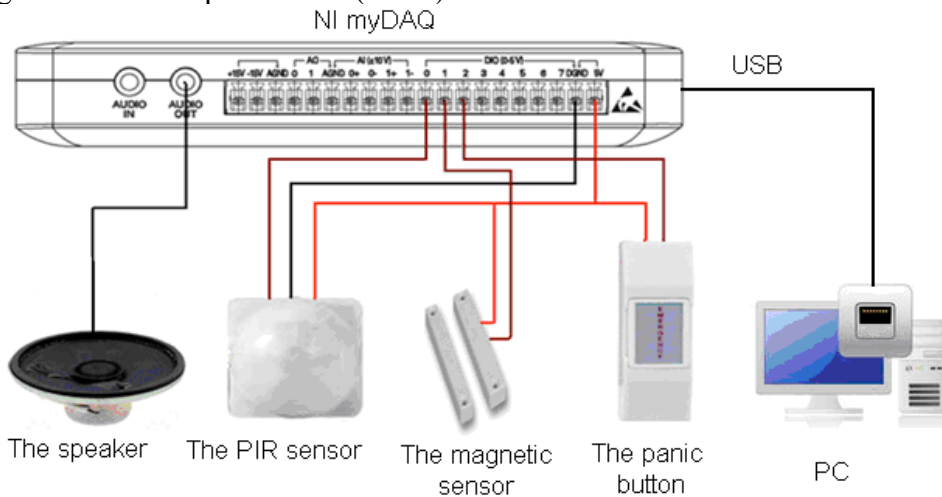

Figure 6. The required application components

## 2. REALIZATION OF VIRTUAL INSTRUMENT

The front panel window is the user interface for the VI. Figure 7 shows a front panel window of the VI.

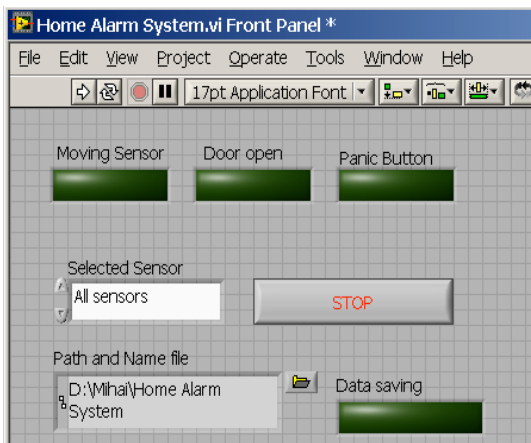

Figure 7. The front panel window of the Home Alarm System

The front panel is made with:

- 4 LED Indicator according to each sensor and one for saving data;

- one Control Enum (Selected Sensor) with 4 positions:

- 0-All sensors
- 1-Door open
- 2-Moving sensor
- 3-Panic Button

- one STOP button;
- one Control Path, for saving data in a file.

It will introduce you to the block diagram, a DAQ Assistant VI, they will select 3 digital inputs, suitable for each sensor.

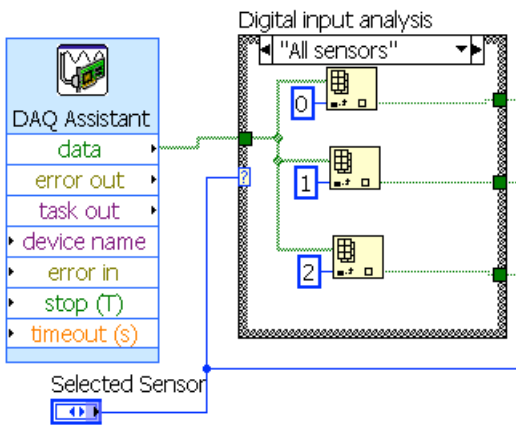

Figure 8. Digital input

Boolean outputs of the structure Case (True or False), will be used for the command Case structure of the audio output, to select the frequency of the audio signal and for command of the function of writing data to the file.

Next, will be presented to, the four subdiagram corresponding to the 4 cases:

- 0-All sensors
- 1-Door open
- 2-Moving sensor
- 3-Panic Button

Have used the Index Array functions to return Boolean values corresponding to the 3 sensors. Thus, the first function has the index 0, corresponding to the digital input of the "Moving Sensor", the second function has the index 1, corresponding to the digital input of the "Door open", and the third function has the index 2, corresponding to the digital input of the "Panic Button".

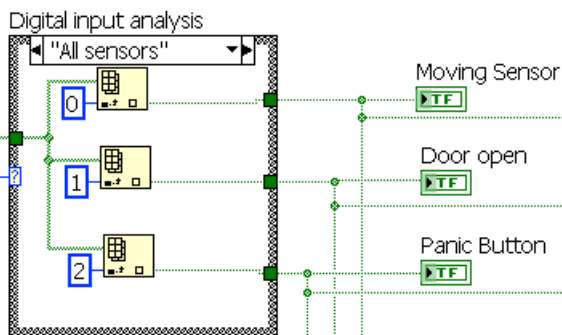

Figure 9. "All sensors" Selected

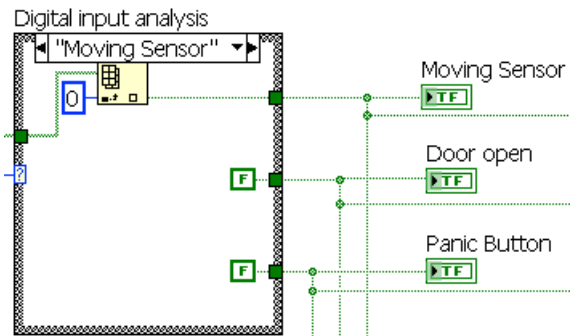

Figure 10. "Moving Sensor" Selected

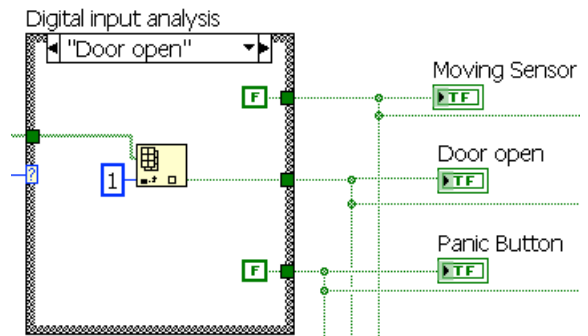

Figure 11. "Door open" Selected

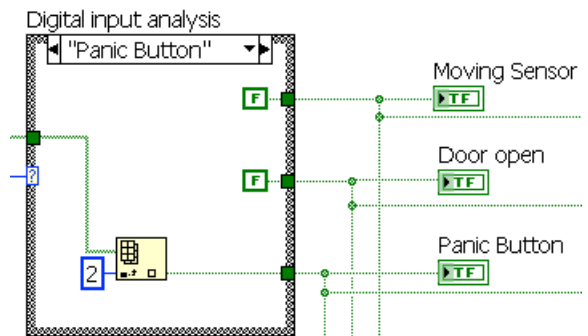

Figure 12. "Panic Button" Selected

1 and 2 "OR" functions are equivalent to the "OR" functions with three entries.

3 function is used to select the frequency to 1000Hz. If the two inputs of the 3 "OR" function ("Moving Sensor" and "Door open") are TRUE, the frequency audio signal is 1000Hz. If the inputs are FALSE the frequency audio signal is 800Hz.

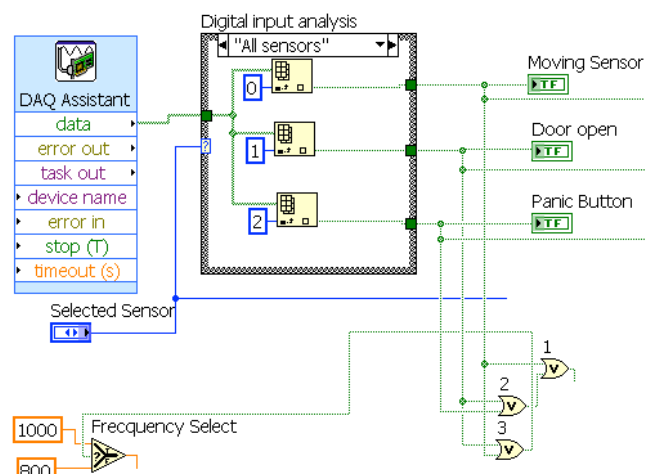

Figure 13. Audio signal Frequency Select

For operating the speaker, will introduce a DAQ Assistant VI, they will select the audio output.

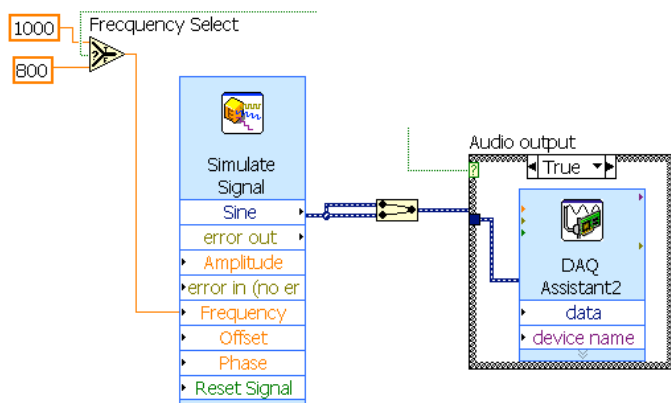

Figure 14. Audio output

For saving the data in a file, we use the function "Write To Measurement File". The message written in the file is composed of: The date, the hour, and the message corresponding to each case: "Moving sensor" Alarm, "Door open" Alarm, and "Panic Button" Alarm.

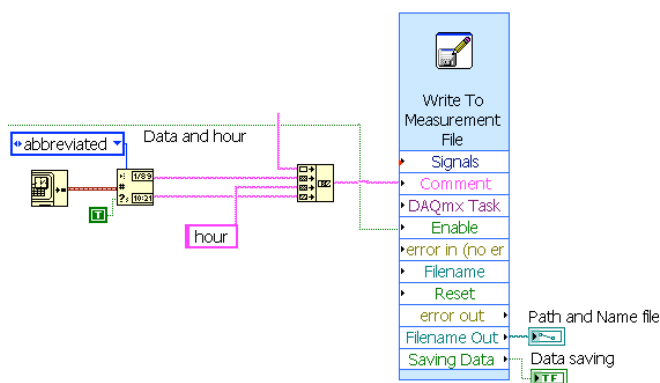

Figure 15. Writing data

### 3. CONCLUSIONS

This paper presents a solution for achieving a Home Alarm System, using a small number of electrical components. Because LabVIEW provides connectivity to any measurement device, you can easily incorporate new LabVIEW applications into existing systems without losing your hardware investment. Regardless of your hardware

requirements, LabVIEW provides an interface to make connecting to your I/O easy.

Compared with classical way of experimental investigation, main advantage of using DAQ with virtual instrumentation interface by LabVIEW software is in flexibility concerning requirements that could be also modify during experiments realisation.

### 4. REFERENCES

1. Bogdan M., Panu M., Viorel A., Teaching data acquisition on a virtual laboratory, the 4thBalkan Region Conference on Engineering Education, ISSN 1843-6730, 12-14 July, Sibiu, 2007.
2. Bogdan, M., Measurement experiment, using NI USB-6008 data acquisition, Journal of Electrical and Electronics Engineering, Vol.2, Nr.1, 2009, ISSN 1844-6035, University of Oradea Publisher, 2009.
3. Bogdan, M., Sampling rate and aliasing on a virtual laboratory, Journal of Electrical and Electronics Engineering, Vol.2, Nr.2, 2009, ISSN 1844-6035, University of Oradea Publisher, 2009.
4. Bogdan, M., Virtual instrument, for frequency measurement and spectral analysis, Journal of Electrical and Electronics Engineering ISSN/ EISSN: 18446035 20672128 Year: 2011 Volume: 4 Issue: 1 Pages: 19-22.
5. National Instruments LabVIEW Graphical Programming Course, 2007.
6. A quick guide to NI USB-6008/6009 I/O device, available at: <http://techtach.no/publications/labview>.
7. E. Luther, Electronics Experiments Using USB Data Acquisition, available at: <http://cnx.org/content/col10393/>.
8. <http://zone.ni.com/devzone/cda/epd/p/id/6405>.
9. <https://decibel.ni.com/content/docs/DOC-16843>.