

CATIA v5. NEW NONCONVENTIONAL METHODS OF DESIGN AND MANUFACTURING OF TOP PLATE'S VIOLIN

Lucian GRAMA¹

ABSTRACT:

The CAD-CAM manufacturing represents the new solution for a lot of products. The violin manufacture is not an easy process; it is a complicated one, because the tangential surfaces generations and the controlled thickness over the entire plate is a meticulous work. The new design mediums as CATIA are the ideal solution to obtain a good result. More than design advantage of this design medium and his CAD/CAM resources is the advantage of programming. CATIA offers a good support through his interfaces (SDK), so the engineer can add, modify and delete some components from his project in the fly. In the construction of violin this advantage is imminent, because the manufacturer can update the thickness and iso-lines coordinates at any time, an in this manner the usual critical time compromise and the result perfection is almost there profiting by the resolution of the CNC machine.

KEYWORDS: catia, cnc, manufacturing, catscript, design, violin

1. INTRODUCTION

A computer numerical control (CNC) router that produces high accuracy wood components with minimal operator attention has helped a violin instructor get into the violin manufacturing business in his spare time. Actually, the machine needs little attention. It produces all of the parts needed to make a violin in about 100 hours, compared to the 350 to 400 hours that would be required to make the same parts by hand. In addition, the CNC machine produces the parts to much higher levels of accuracy than can be achieved by hand. The machine's 0.0004 inch resolution and repeatability and 0.003 inch absolute accuracy ensure that each violin component is identical.

2. ABOUT CAD/CAM MANUFACTURING AND CATIA V5

Geometrical shaping is the first and the most important step in a CAM project. It has to be defined the geometrical parameters and the dimensions of the piece in assembly. In our case, using CATIA V5 shape functions, we obtained a photo-realistic image of the violin (Figure 1).

The CATIA's module that permits the basic draw it's called **Draw**. After the border draw or other shapes needed are done, it has to be imported in another module called **Part**, where it is realized the complete violin.

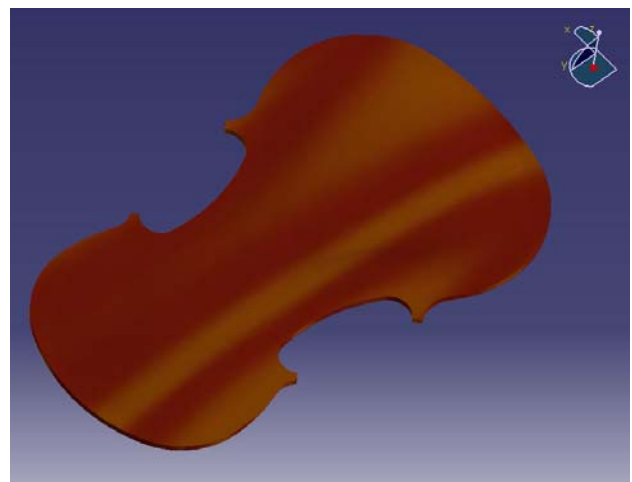

Figure 1

3. VIOLIN CAD DESIGN

First of all, it has to draw the border of the plate violin (Figure 2). The values that define the border and the values that define the iso-lines are based on the specialty literature (see the bibliography).

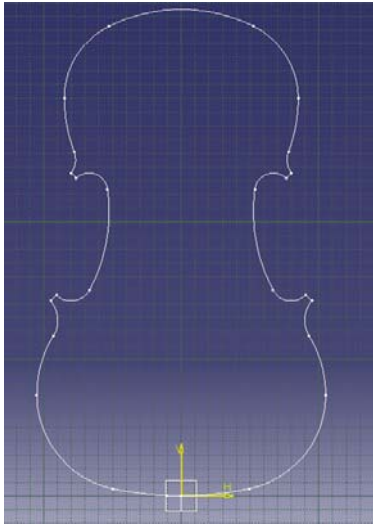

Figure 1

After the border is defined, based on the reference system, it has to build every plane with his attached iso-line. In the Figure 3, is represented in the wire-frame the shape of the violin.

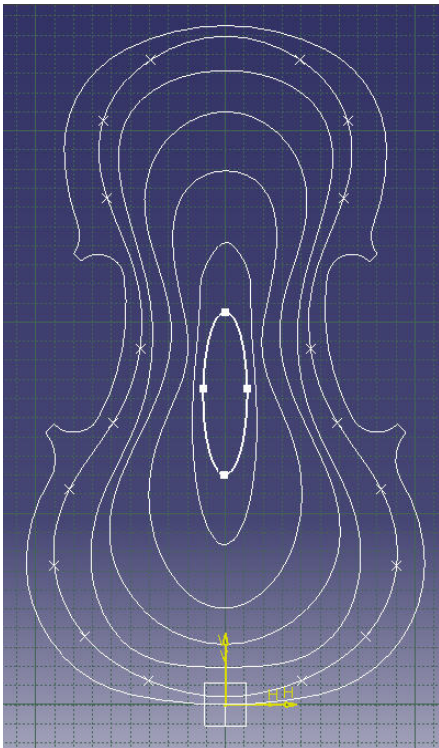

Figure 2

This sketch is the base on which it will be applied different complex CATIA features as: *Fill*, *Sweep*, *Loft*. In the mean time, it has to follow the tangent constraints of the surfaces, generated between that 5 planes defined by the iso-lines.

In the Figure below, Figure 4, it is obtained a rendered version of the top plate violin.

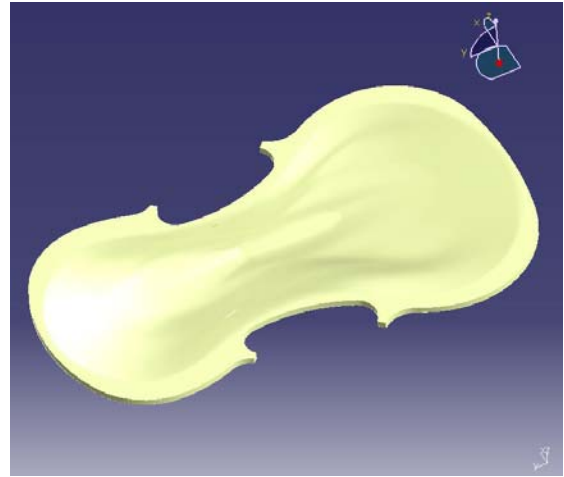

Figure 4

4. CNC MACHINING

A technological paper for a CNC must contain:

- Semi-manufactured dimensions
- positioning on the table in reference by the zero point of the machine
- used tools
- Correction addresses for each tool
- In this particular case it has to keep attention of fiber orientation and of the cutting direction

In the figure below (Figure 5) it is presented the position of the semi-manufacture on the machine table.

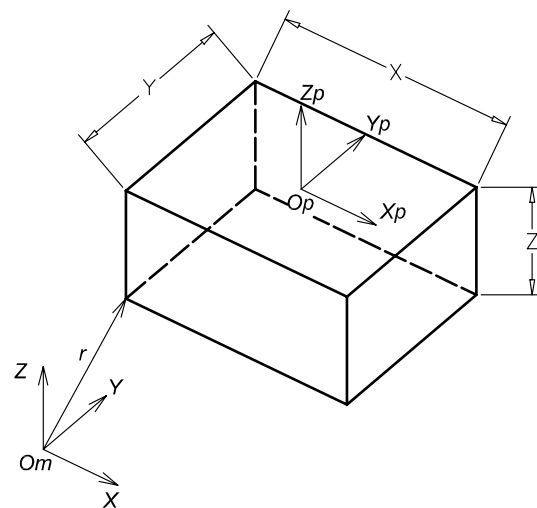

Figure 3

The components of the vector r (r_x, r_y, r_z) it will be the positioning distances of the semi-manufacture by the zero point of MUCN (O_m,xyz). The zero point of the piece (O_p, x_p, y_p, z_p) is the origin of the reference system of the trajectories on which the tool moves. This point is chosen by the programmer and can coincide with the root of the r vector.

From Figure 5, it can express the link between the reference system of the machine and the reference system of the piece, in the case when O_p is in the middle of the superior face of the semi-manufacture.

$$x_p = r_x + \frac{x}{2}$$

$$y_p = r_y + \frac{y}{2}$$

$$z_p = r_z + z$$

The reference system of the piece can be chosen anywhere, but there are some principals in the practice: Origin of the O_p is chose vertically in the must upper point of the semi-manufacture. In the XY plane, the origin is chosen in the middle of the base of the semi-manufacture, in a corner or in the middle of any side.

In the figure below (Figure 7), it can see a caption from a video simulation made in CATIA. The simulation represents the sweeping of the violin.

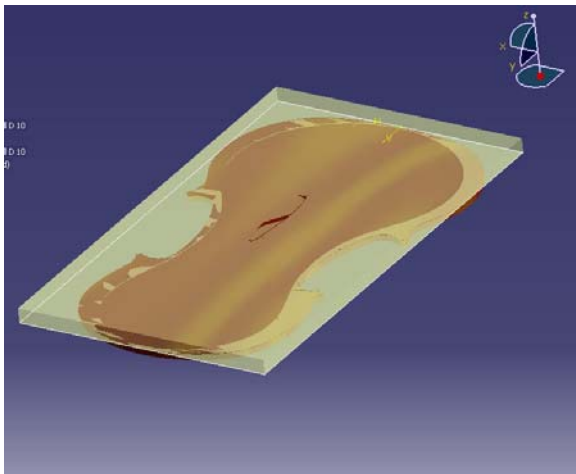

Figure 6

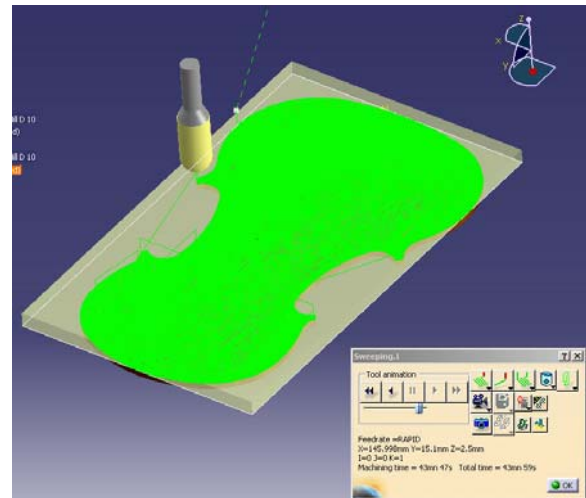

Figure 7

5. DESIGN AND CATIA PROGRAMMING - CATSCRIPT

First of all, it has to be mentioned that in the free parametric modeling is used as database, an Excel Sheet. The values are presented in figure below (Figure 8). Each plan has a number of control points that define an iso-line. These values can be changed at desire, respecting in approach some values to respect the violin geometry. In the image below are presented the values for the first plan –Plan 0-. ‘Dist’ keyword represents the distance in millimeters from the previous plan.

	A	B	C
1	StartPlan.0		
2	Dist	2	
3	CtrlPoint.1	349.4	0
4	CtrlPoint.2	337.152	-39.339
5	CtrlPoint.3	305.204	-64.468
6	CtrlPoint.4	264.491	-62.309
7	CtrlPoint.5	227.124	-48.112
8	CtrlPoint.6	185.881	-44.937
9	CtrlPoint.7	147.092	-59.157
10	CtrlPoint.8	112.715	-82.048
11	CtrlPoint.9	72.813	-90.265
12	CtrlPoint.10	35.849	-74.216
13	CtrlPoint.11	12.629	-40.362
14	CtrlPoint.12	4.098	0
15	EndPlan.0		

Figure 8

The distance ‘Dist’ is modified programmatically using this sequence of VBA code:

```
Set reference1 =  
part1.CreateReferenceFromObject  
(hybridShapePlaneExplicit1)  
Set hybridShapePlaneOffset1  
=hybridShapeFactory1.AddNewPlaneOffset  
(reference1, 2.000000, False)  
- where 2.0000 represents the distance  
in millimeters
```

To change the Control Point's values it has to use this section of VBA Code:

It used the current document

```
Set partDocument1 = CATIA.ActiveDocument  
Set part1 = partDocument1.Part  
Set bodies1 = part1.Bodies  
Set body1 = bodies1.Item("PartBody")
```

To modify the coordinates of a Control Point it has to use the Sketcher module, so we have to initialize him:

```
Set sketches1 = body1.Sketches  
Set sketch1 = sketches1.Item("Sketch.6")
```

Open the Sketcher Editor:

```
Set factory2D1 = sketch1.OpenEdition()
```

Update a new instance of the current geometrical Element associated with the current Spline where the Control Point is:

```
Set geometricElements1 =  
sketch1.GeometricElements  
Set spline2D1 =  
geometricElements1.Item("Spline.1")
```

Access the desired Control Point:

```
Set controlPoint2D1 =  
spline2D1.GetItem("CtrlPoint.12")
```

Set the new values from the current Control Point

```
controlPoint2D1.SetData 49.267206,  
258.063000
```

Taking as example this piece of VBA code, it has to be covered each plane and each Spline/Control Point that defines an Iso-line.

6. CONCLUSION

The presented solution can be a big step in violins manufacturing but it has to admit that the manufacture of a violin is more than a simple profession. To build a violin it has to take in consideration more domains of examination, of the sculptor, of the acoustician, of the musician. Isn't an easy job to build a violin taking in consideration the more constraints that appear in the geometry of a violin. This paper proposed a new approach about a traditional profession, where the precision is a key word and when we talk about the precision, we talk about the precision of machine-tools.

7. REFERENCES

- > Fundamentals of milling - Manual de utilizare, Parametric Tehnology Corporation, 2000
- > Mold design – Manual de utilizare, Parametric Tehnology Corporation, 2000.
- > Ion. L. Lăzăroiu – Vioara. Reghin orașul viorilor.
- > Other Internet resources

1. "Petru Maior" University Tg-Mures, Romania

E-mail: lgrama@upm.ro