

EXPERIMENTAL RESEARCH ON DIMENSIONAL PRECISION OF SMALL REVOLUTION SURFACES PROCESSED BY WEDM

Denes Calin¹ and Grecu Valentin²

¹“Lucian Blaga” University of Sibiu, Romania, calin.denes@ulbsibiu.ro

²“Lucian Blaga” University of Sibiu, Romania, valentin.grecu@ulbsibiu.ro

ABSTRACT: The paper introduces first the principle of processing small-surface parts using the wire electrode discharge machining (WEDM) and then approaches the issue of dimensional precision that this kind of processing features. There are presented the results of experimental research carried out using the Taguchi method, which show the extremely high precision of this method, a precision characteristic to fine mechanics.

KEY WORDS: wire electrical discharge machining, dimensional precision, the optimization of the processing, the Taguchi method

1. GENERALITIES

Generating small-surface revolution parts using WEDM requires at least one extra generating motion, besides those provided by present-day machines. The part subjected to processing has to be spun around its own axis. The specific literature in this field is rather scant, part from the author’s papers.

In order to make the small-surface parts’ WEDM processing possible, the machine-tools must be equipped with special technologies, capable of ensuring a variable rpm for the part.

Figure 1 presents, the principle, construction and also the way in which such a piece of equipment works. The part has its axis positioned in a horizontal plain and can execute a revolution movement (A), towards the wire electrode’s (WE) feed rate (v_e) or contrary to it. The revolution movement is given by the DC motor through a reducer R, connected to the engine by means of the elastic coupling C. The latter has a self-centering fastening system for the part to be processed and it is mounted on the exit shaft. The rotation of the part can be variable, the variation being conferred by the DC motor’s supply voltage produced by the power unit (SA).

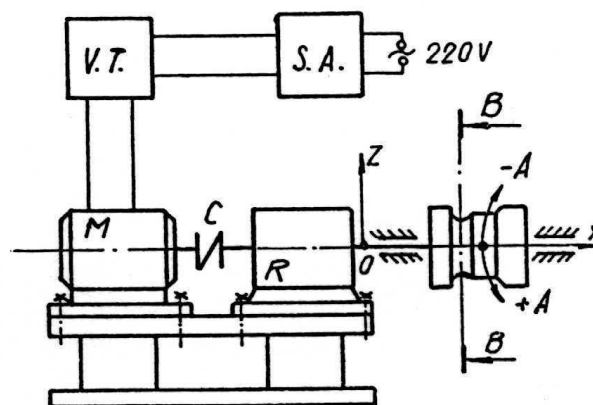
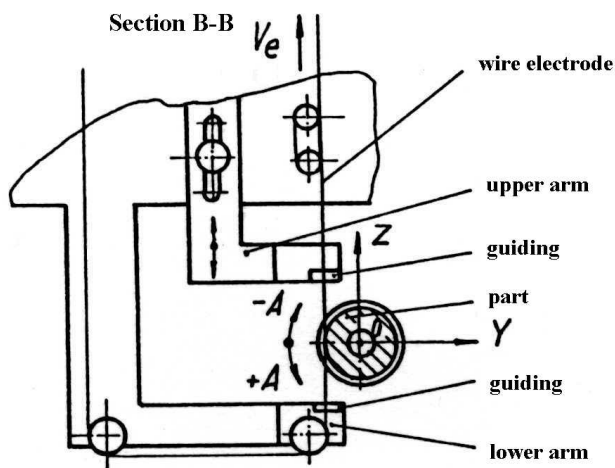

Figure 1. The device used in processing revolution surfaces

The WEDM shaping of the parts necessitates the removal of the entire tooling allowance in successive strata using the WEDM.

Thus there can be obtained different forms of revolution surfaces on parts made of sintered hard alloy; alloys containing graphite and copper or other types of steel used frequently in machine-tool

manufacturing. Figure 2 shows a few examples of surfaces that can be achieved using the proposed device. Generally, the output of this device is represented by small, complexly-shaped roller cutters, rotating electrodes used in WEDM or electrochemical processing, like circular cutters used in lathing geometrically-complex small recesses.

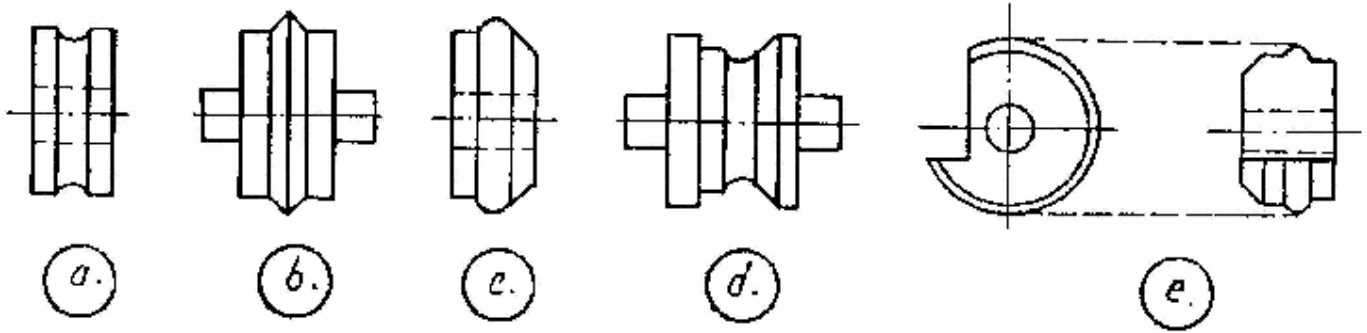

Figure 2. Samples of revolution surfaces

The efficient application of this proposed shaping technology requires the optimization of the parameters involved in the processing according to the aims pursued. Throughout this paper, there will only be analyzed the dimensional precision specific to this processing.

2. EXPERIMENTAL CONDITIONS

The experimental research was carried out using a revolution surfaces' generating device mounted on a

machine called AGIECUT DEM 315. Figure 3 shows the experimental stand. The processed-to-be part 7, placed between the machine's (1) arms 3 and 8 is fastened in the generating device, which is mounted on table 6 by means of prop 5, being supplied by a power source (2).

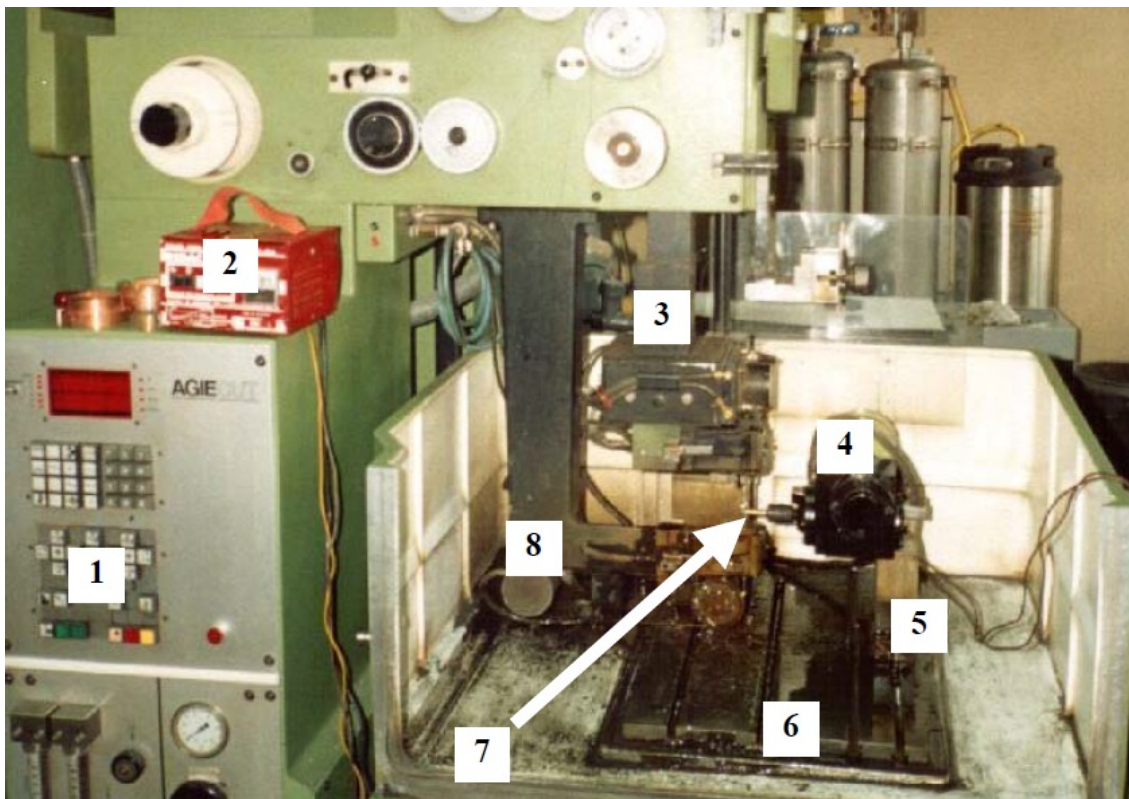

Figure 3. Experimental stand

The optimization “target” criterion that was sought was the dimensional precision of the processing. Experiments were done in accordance with a Taguchi experimenting plan, described by an L_8 matrix, whose influencing factors are presented in table 1. The Taguchi experimenting-plan method deals with the mean and the variability of the technological characteristics measured indivisibly.

The sound/noise (S/N) ratio takes simultaneously into consideration the value of the controlled characteristic (the signal) as well as the undesired variability of this measurement, caused by perturbations (noises) that need to be fought against. The greater the algebraic value of the sound/noise ratio is, the greater the generated loss will be and the more the process's performance will increase.

Table 1. Controlled factors and levels of adjustment

Controlled factors			Levels of adjustment	
Symbol	Specification	Notation	Level 1	Level 2
A	The pitch between 2 successive passes	p [mm]	0.1	0.5
B	The discharging current's intensity	I_d [A]	0.3	1
C	The duration of current impulses	t_{ii} [μ s]	12	36
D	The dielectric's conductivity	K [μ S/cm]	20	75
E	The wire electrode's take speed	v_e [mm/s]	20	50
F	The WE's tensile force	F_T [daN]	0.4	0.8

There were processed successive semi-round recesses whose radius was $R=0.5$ mm. The parts that were used were cylindrical ones, 8 mm in diameter, made of 195Cr115 (STAS 3611-88) alloy steel, temper-hardened at 58 HRC (figure 4).



Figure 4. Part sample

The wire electrode employed was made of brass and its diameter measured 0.1 mm. The measurements were taken for 5 samples pertaining to each experiment ($i1 \div i5$), using a Karl Zeiss Jena universal microscope (figure 5). In order to generate the recesses that were 0.5 mm in diameter, needed in order to determine the processing's dimensional precision, the wire electrode was programmed to move according to trajectories equidistant to the generating curve like those presented in figure 6.

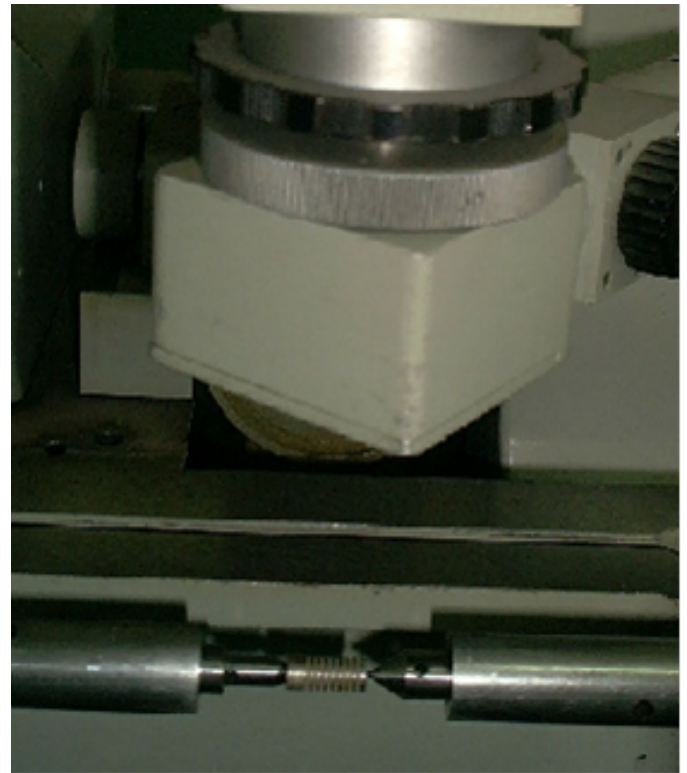

Figure 5. The determination of the processing's dimensional precision

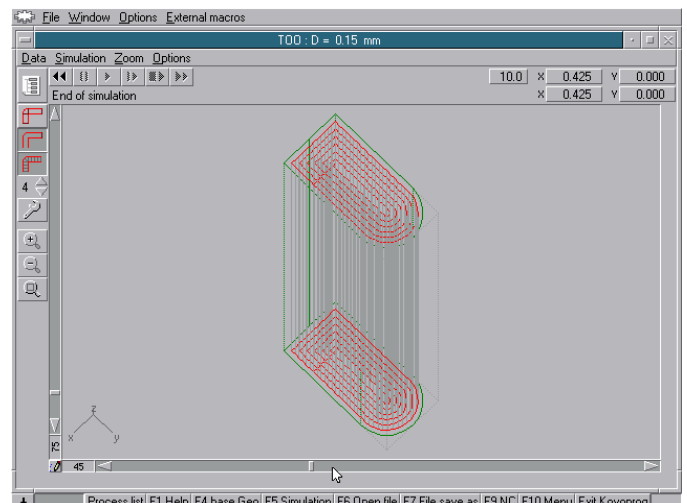

Figure 6. The wire electrode's trajectory

3. EXPERIMENTAL RESULTS

The experimental data was processed using some Excel worksheets, based on the mathematical algorithm described by [1]. A screen capture showing the worksheet is presented in figure 7.

The findings and the recorded answers were taken from the Excel calculus registry and are presented in tables 2 and 3. In figure 8 and 9 we can see a graphical representation of the resulted processed experimental data.

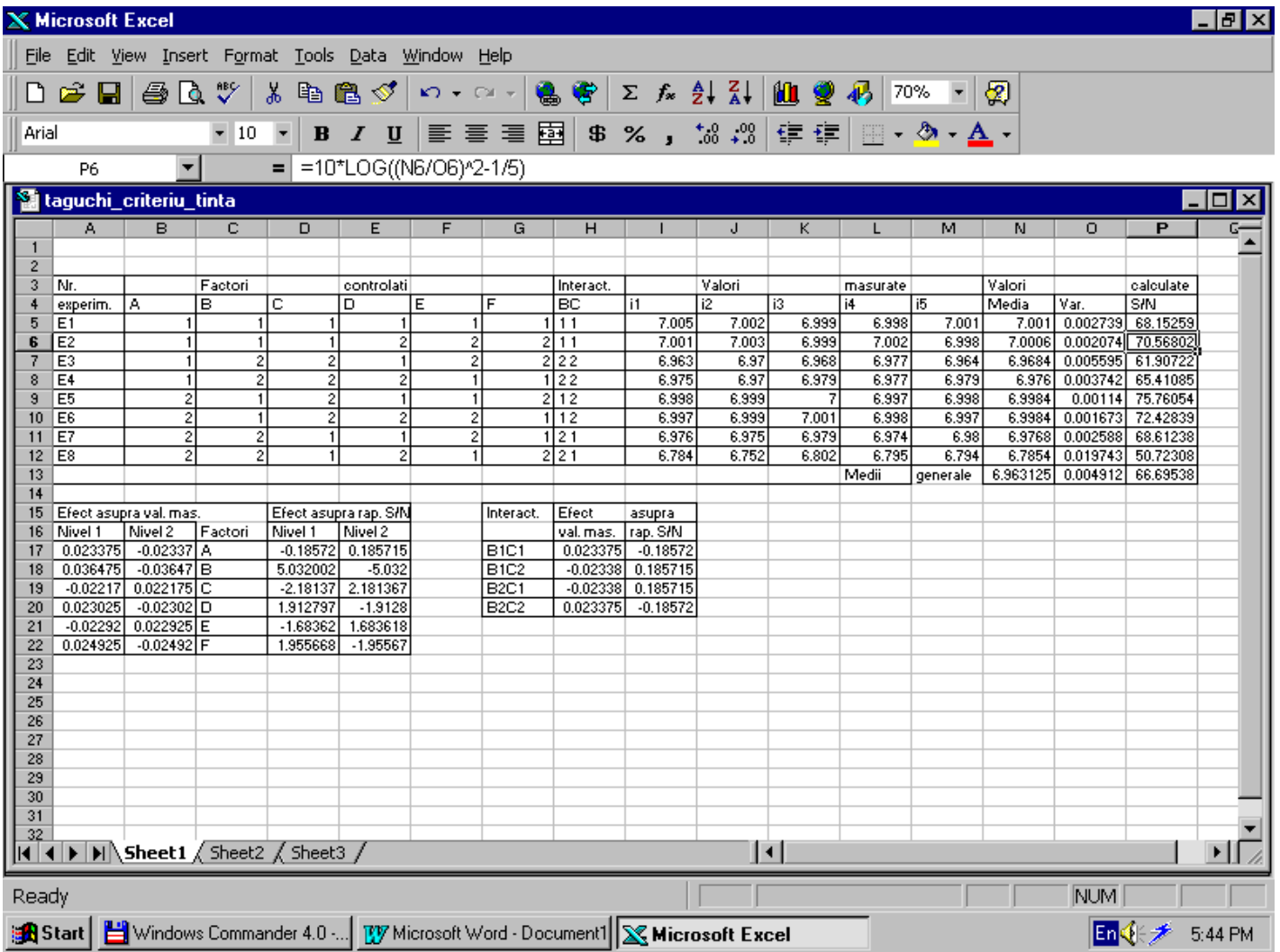

Figure 7. An Excel data-processing worksheet

Table 2. Results of experiments regarding dimensional precision

No. of experiment.	Controlled factors						Interaction	Measured values for d [mm]					Calculated values		
	A	B	C	D	E	F		BC	i1	i2	i3	i4	i5	Mean	Var.
E1	1	1	1	1	1	1	1 1	7.005	7.002	6.999	6.998	7.001	7.001	0.002739	68.15259
E2	1	1	1	2	2	2	1 1	7.001	7.003	6.999	7.002	6.998	7.0006	0.002074	70.56802
E3	1	2	2	1	2	2	2 2	6.963	6.97	6.968	6.977	6.964	6.9684	0.005595	61.90722
E4	1	2	2	2	1	1	2 2	6.975	6.97	6.979	6.977	6.979	6.976	0.003742	65.41085
E5	2	1	2	1	1	2	1 2	6.998	6.999	7	6.997	6.998	6.9984	0.00114	75.76054
E6	2	1	2	2	2	1	1 2	6.997	6.999	7.001	6.998	6.997	6.9984	0.001673	72.42839
E7	2	2	1	1	2	1	2 1	6.976	6.975	6.979	6.974	6.98	6.9768	0.002588	68.61238
E8	2	2	1	2	1	2	2 1	6.784	6.752	6.802	6.795	6.794	6.7854	0.019743	50.72308
General means												6.963125	0.004912	66.69538	

Table 3. Table of answers for the dimensional precision

Effects exerted upon the measured values		Factors	The effect on the S/N ratio		Interaction	The effect on	
Level 1	Level 2		Level 1	Level 2		meas. value.	S/N ratio
0.023375	-0.02337	A	-0.18572	0.185715	B1C1	0.023375	-0.18572
0.036475	-0.03647	B	5.032002	-5.032	B1C2	-0.02338	0.185715
-0.02217	0.022175	C	-2.18137	2.181367	B2C1	-0.02338	0.185715
0.023025	-0.02302	D	1.912797	-1.9128	B2C2	0.023375	-0.18572
-0.02292	0.022925	E	-1.68362	1.683618			
0.024925	-0.02492	F	1.955668	-1.95567			

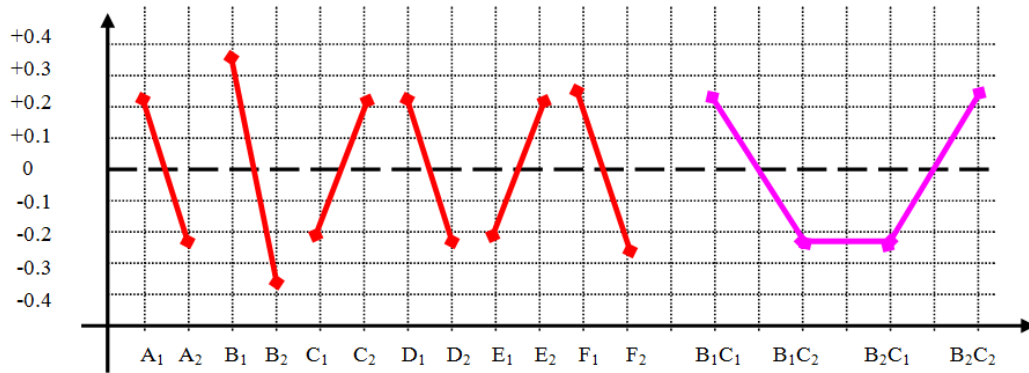

Figure 8. The effects on the measured value of the diameter (dimensional precision)

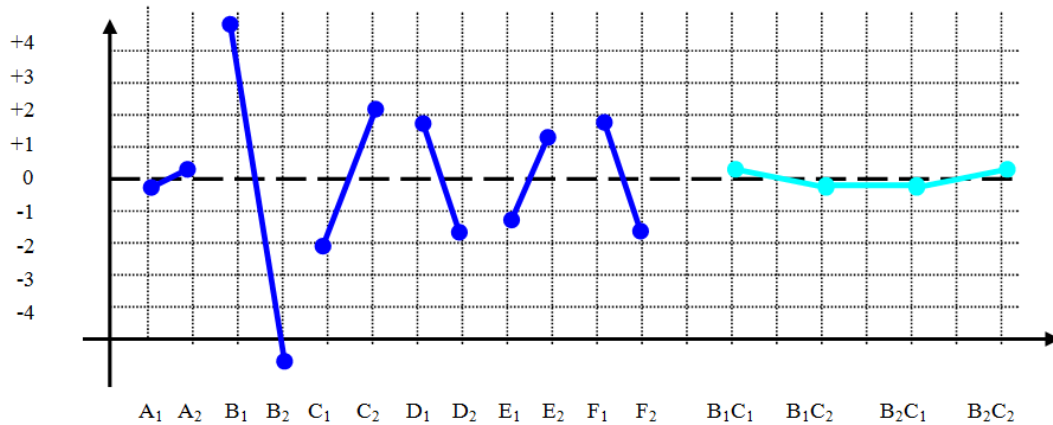

Figure 9. Effects exerted upon the size of the S/N ratio regarding the dimensional precision

Analyzing the results that were obtained (figure 8 and 9), we realize that in order to get the best dimensional precision during the processing of revolution surfaces, the pitch between the WE's trajectories (A) will be established according to level 2 (A2). This is because its direct influence on the diameter, though great, we are more interested in the values' dispersion, albeit the influence it exerts upon the measured value is relatively insignificant.

This choice is also justified by the greater productivity yielded by a higher pitch, that which is economically favourable. The current's intensity is the major factor, from both points of view: the dimensions obtained and the dispersion of their values.

We will adopt level B1, since a lower discharging current intensity produces shallower erosion craters.

For the duration of the processing's impulse we will adopt value C2, because we'll also take into account the BC interaction, which greatly influences the diameter but is almost irrelevant in comparison to the results' variance.

The adequate level of the dielectric's conductivity is D1, the level of influence for the average value and the scattering of the results being almost equal.

E2 is adopted the WE's take speed; due to the tiny influence upon the S/N ratio we can also choose

level E1 which will be manifested in a more economical use of the WE, this being especially relevant when the latter is pricy.

The influence exerted by the WE can almost be overlooked and so we will adopt level F1.

Thus, the values of the factors will be defined by the following combination: A2, B1, C2, D1, E2, and F1.

Note that in practice we are even acquainted with the tolerance required by the processed diameters, in which case, the Taguchi method can also forecast the results of various combinations of the above-mentioned factors [1]. It is also recommended that the estimates be validated by at least one trial experiment. [1].

The Taguchi method can – besides establishing optimal values for the technological parameters – rank influencing factors. The experiments undertaken show that, as regarding dimensional precision, the factors considered can be ranked, according to their importance, as following: B, C, F, D, E, A.

4. CONCLUSIONS

WEDM can yield favourable dimensional precisions during the processing of revolution surfaces, worthy of fine mechanics.

The experiments have produced dimensional precisions corresponding to the 3-5 precision scales. These numbers undoubtedly show that the presented processing is situated in the field of finishing processing.

5. REFERENCES

1. Alexis, J. *Taguchi Method in industrial practice. Experience plans. (Metoda Taguchi in practica*

industriala. Planuri de experienta), Bucharest, Technical Publishing House, 1999.

2. Denes, C. *Contributions on Wire Electrical Discharge Machining. PhD Thesis (Contribuții asupra prelucrării prin eroziune electrică cu electrod filiform. Teza de doctorat.)* Lucian Blaga University of Sibiu, 2002.