

## SOME CONSIDERATION REGARDING THE LASER PARAMETERS IN THE WELDING PROCESS

Marcel Sabin POPA<sup>1</sup>, Mircea Filon PRECUP<sup>2</sup>, Glad CONTIU<sup>3</sup>, Dan PREJA<sup>4</sup>

### ABSTRACT:

The laser machining is an unconventional technology. Compared with the conventional machining are mentionable: the high speed of machining, the high precision, the high energy and the low thermo influences of the area. The welding process is directly determined by the following parameters: pulse power, pulse duration and focus position. These three parameters have particular values for different type of alloys, different working speeds and different protective gases. The team made some researches regarding the influence of those parameters on the width, on the deep and on the surfaces quality of the seam welding. The results of these researches can be used for the simulation and the optimization of the machining. Using the simulation we can obtain better characteristics of the welding

**KEYWORDS:** laser welding, laser parameters

### 1. INTRODUCTION

The laser beam as a thermal device is a relatively new practice in finishing technologies. In order to process raw materials, one can use the following procedures: cutting, welding, local hardening and drilling.

The advantages of laser beam cutting compared to other methods are: greater precision, increasing work speed, allowing the point-like processing of the piece - this is a process that does not imply touching the piece with an instrument (beam).

The use of this procedure reduces the heating of the working area because the energy is introduced faster and on a small surface – this is why large power densities can be reached. Other advantages are flexibility and accessibility.

These researches were made on the Trumpf HL54P laser equipment which has an Nd: YAG rod.

Nd: YAG lasers emit light in the near infrared range, at a wavelength of 1.06 $\mu\text{m}$ . This means that the light emitted by Nd: YAG lasers is almost in the visible range. The laser light of a Nd: YAG laser can be routed through glass optics and optical fibers.

In processing, the laser power absorbed by the material causes the latter to heat up

rapidly and - if the intensity is sufficiently high - results in melting or even vaporization of the material. As better a material can absorb the wavelength of a laser, then greater the amount of energy that can be introduced into the material. This means that the efficiency of the laser beam increases proportionately with the capacity of the material to absorb the laser wavelength.

The following question is therefore especially important in material processing: how well do different materials absorb the wavelength of Nd: YAG lasers.

The diagram illustrates the absorption capacity of different material groups as a function of the wavelength.

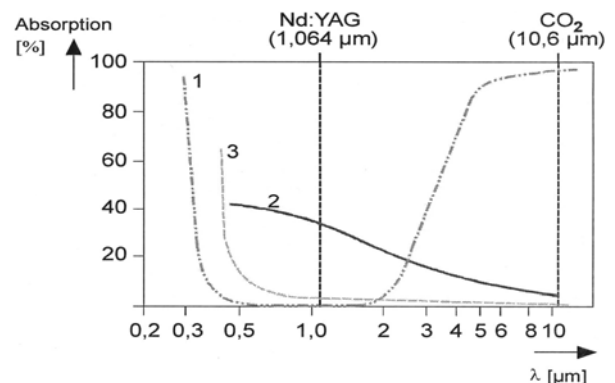

**Fig. 1. Absorption capacity for: 1-glass; 2-transition metals (iron, nickel); 3-Other metals (copper, aluminium, silver, gold)[4]**

The degree of absorption varies with the material and with the wavelength of the impinging laser light. Metals can better absorb the wavelength of the Nd: YAG laser than that of a CO2 laser.

For Nd:YAG lasers with one cavity, up to 800W power ratings can be attained with one single laser rod. The beam parameter product in this case is about 30 mm\*mrad. Although higher laser power could be generated by using larger laser rods or higher ion concentration levels, the resulting beam would be of very poor quality.

We need some safety measures because the wavelength of the Nd: YAG laser is almost in the visible range, the human eye is particularly vulnerable. Suitable safety measures are therefore imperative for this type of laser.

## 2. THEORETICAL ASPECTS

There are some factors which influence the welding result like pulse power, pulse duration, pulse energy, pulse repetition frequency, average laser power, focus position, protective gas type and supply.

The average power of pulsed ( $P_{av}$ ) lasers is the average value of the power during a longer time. In spite of high pulse powers (several kilowatts) a small average power (few 100 Watt) may be the result, if the pulse duration is small in comparison to the break between the pulses.

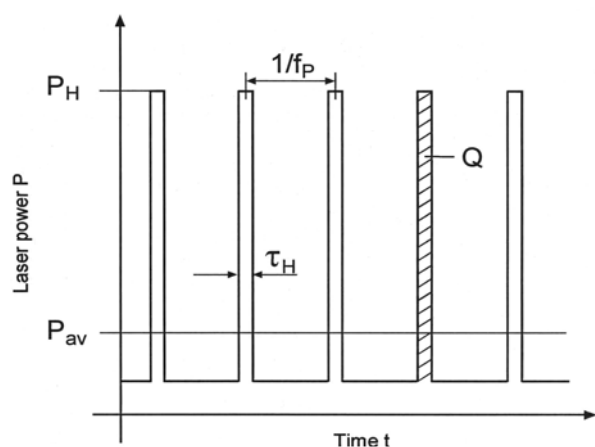

**Fig. 2. Laser power diagram:  $P_H$ —pulse power in case of pulsed lasers;  $P_{av}$ —average power;  $Q$ —pulse energy;  $\tau_H$ —pulse duration;  $f_p$ —pulse repetition frequency[4]**

The average power is the product of pulse power, pulse duration and pulse repetition frequency:

$$P_{av} = Q \cdot f_p = P_H \cdot \tau_H \cdot f_p \quad (1)$$

The pulse repetition frequency ( $f_p$ ) indicates the number of laser pulses per second.

The pulse energy ( $Q$ ) indicates the quantity of energy which is contained in a laser pulse. In the power-time-diagram of a laser pulse corresponds to the pulse energy of the surface in the laser pulse.

$$Q = P_H \cdot \tau_H \quad (2)$$

The pulse duration ( $\tau_H$ ) indicates the time during which pulse power is emitted in case of pulsed lasers.

For material processing the laser beam has to be focused to the necessary power density using convex lens.

The size of the focal spot depends on the laser divergence  $\theta$  and the focal length of the lens  $f$ . The length of the optical axes in the focus, on which the focal diameter  $d_{of}$  changes only negligible, is called depth of focus ( $Z_R$ ).

$$d_{of} = f \cdot \theta \quad (3)$$

$$Z_R = \frac{f^2 \cdot \theta}{d_0} = \frac{d_{of} f}{\theta_f} \quad (4)$$

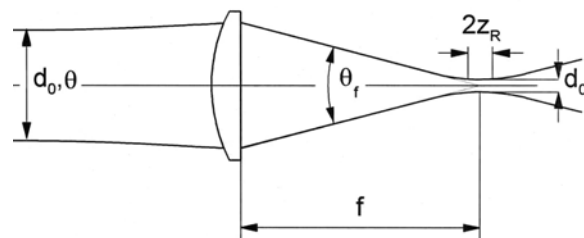
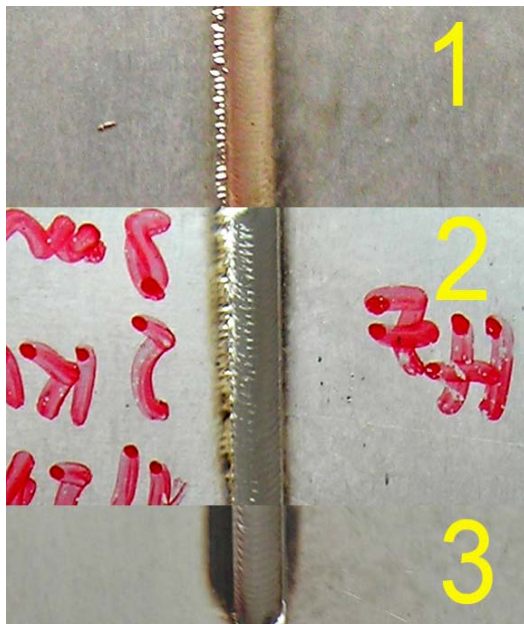

**Fig. 3. The depth of focus ( $Z_R$ ).  $f$  - focal length of the lens;  $\theta$  - divergence;  $\theta_f$  - divergence of the focused beam;  $d_0$  - waist diameter;  $d_{of}$  - focal diameter.[4]**

The product from divergence and beam diameter  $\theta \cdot d_o$  is constant in an optical reproduction. An increase of the divergence can be achieved by reduction of the focal length of the lens. The focal diameter becomes as a result smaller and a higher power density can be achieved. But the depth of focus decreases.

### 3. EXPERIMENTAL REZULTS

The team has studied the influence of the pulse power, the pulse duration and the focus position in two cases: overlap welding and edge-to-edge welding. By overlapping the spots we obtained the seam. The diameter of the spot is determined by the focus position. In the first case we modified the pulse power all other parameters being constant:  $\tau_H=8$  ms for overlap welding,  $\tau_H=10$  ms for edge-to-edge welding,  $f_p=6$  Hz and  $d_{of}=1.2$  mm.



**Fig. 4. Overlap welding with pulse power:**  
1)  $P_H= 2.5KW$ ; 2)  $P_H= 2KW$ ; 3)  $P_H= 3KW$ .

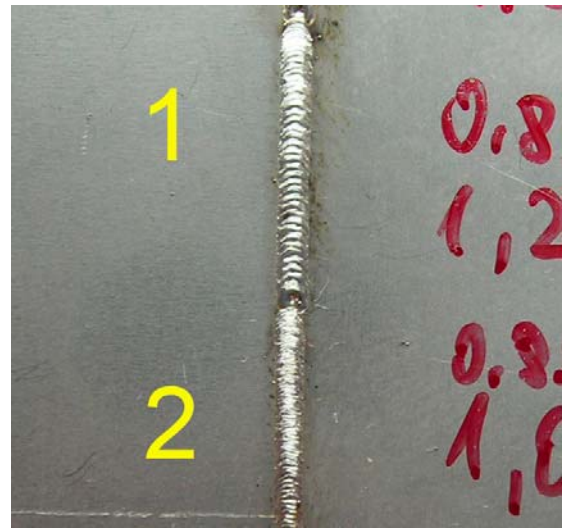

**Fig. 5. Edge-to-edge welding with pulse power:** 1)  $P_H= 1.2KW$ ; 2)  $P_H= 1KW$ .

Increasing the pulse power, we get a better depth of the seam and a better surface of the seam, but the laser beam produces splashes and a slot close to the seam.

In the second case we modified the pulse duration all other parameters being constant:  $P_H=2KW$  for overlap welding,  $P_H=1.1KW$  for edge-to-edge welding,  $f_p=6$  Hz and  $d_{of}=1.2$  mm.



**Fig. 6. Overlap welding with pulse duration:** 1)  $\tau_H=8ms$ ; 2)  $\tau_H=10ms$ .

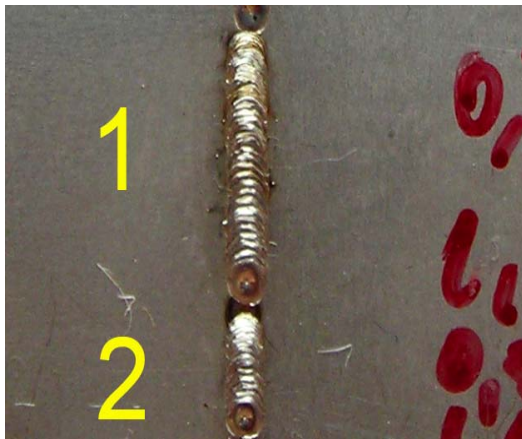

**Fig. 7. Edge-to-edge welding with pulse duration: 1)  $\tau_H=10ms$ ; 2)  $\tau_H=9ms$ .**

The increasing of the pulse duration and the pulse energy too, is followed by the increasing of the dimensions of the seam, width and depth. The surface of the seam is not good, it can be seen the the trace of the spots. If the pulse duration is too long, this will be followed by splashes and an increased heat of the metal close to the seam.

In the third case we modified the spot diameter by modifying the focus position all other parameters being constant:  $P_H=2KW$ ,  $\tau_H=8$  ms for overlap welding and  $\tau_H=10$  ms for edge-to-edge welding,  $f_p=6$  Hz.

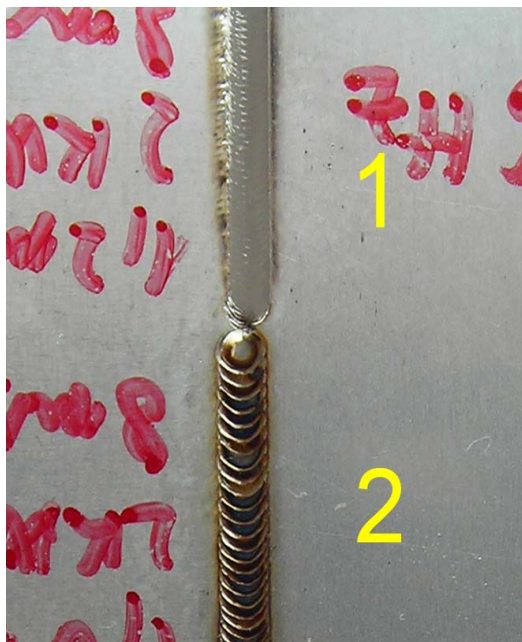

**Fig. 8. Overlap welding with spot diameter: 1)  $d_{of}=1.2mm$ ; 2)  $d_{of}=1mm$ .**

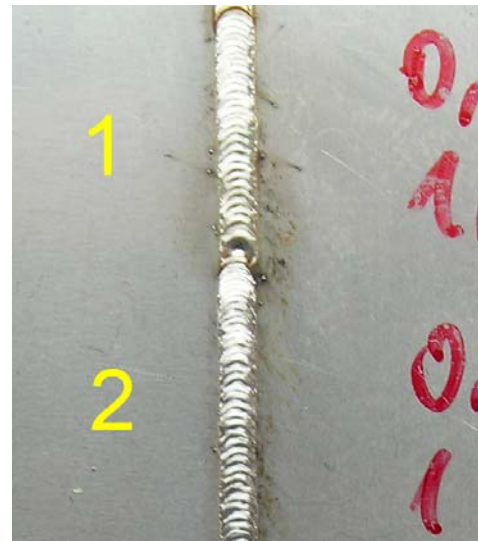

**Fig. 9. Overlap welding with spot diameter: 1)  $d_{of}=0.8mm$ ; 2)  $d_{of}=0.85mm$ .**

The increasing of the focus position will be followed by the improving of the seam's surface and will reduce the splashes. However, the depth will be reduces too.

#### 4. CONCLUSION

The aim of this experiment was to identify the influence of each of the laser parameters on the welding process.

In this paper, the team analyzed three laser's parameters: pulse power, pulse duration and focal position. The amount of melt material depends on the energy transferred by the laser beam in the material to be weld. The energy value represents the product of the value of the pulse power and the value of the pulse duration. Focal position is important because in case on overlap welding the laser beam has to be focused between the two metal sheets.

The pulse power has to be set in order to avoid the splashing. A longer duration of the pulse determines a bigger volume of the melt material, covering the slots close to the seam. A longer duration of the pulse decreases the feed speed.

Considering that the modifying of one parameter influences directly or indirectly the process of welding, a simulation and an optimization of the process is required. This will significantly reduce the time of the process and the losses of the material

The researches were made on the Trumpf HL54P laser equipment. The results of these researches can be used for the simulation and the optimization of the machining to improve the quality of the welding.

#### REFERENCES

- [1] Helmut HÜGEL, *Strahlwerkzeug Laser*, Teubner Verlag Stuttgart, 1992
- [2] Walter KOECHNER, *Solid-State Laser Engineering*, 3rd ed., Springer-Verlag, 1992
- [3] Marcel Sabin Popa, *Tehnologii si masini neconventionale, pentru mecanica fina si mecatronica*, U.T. Pres Cluj-Napoca, 2005

- [4] Trumpf Laser, *LCB Laser Devices. Basic Training*, Trumpf Laser GmbH+Co.KG, 2005

#### AUTHORS

- 1. Professor Ph. D. , Marcel Sabin POPA, Technical University of Cluj-Napoca, Romania, [Marcel.Popa@tcm.utcluj.ro](mailto:Marcel.Popa@tcm.utcluj.ro) , 0264 401 635
- 2. Ph. D. student, Mircea Filon PRECUP, Technical University of Cluj-Napoca, Romania, [Mircea.Precup@tcm.utcluj.ro](mailto:Mircea.Precup@tcm.utcluj.ro) , 0264 401 634
- 3. Ph. D. student, Glad CONTIU, Technical University of Cluj-Napoca, Romania, [Glad.Contiu@tcm.utcluj.ro](mailto:Glad.Contiu@tcm.utcluj.ro) , 0264 401 634
- 4. Ph. D. student, Dan Preja, Technical University of Cluj-Napoca, Romania, [danpreja@yahoo.com](mailto:danpreja@yahoo.com)