

MODULAR EQUIPMENT FOR ELECTROCHEMICAL DEBURRING

Gabriela-Marina ENE¹, Alexandra-Daniela COȚOFANĂ², Liviu-Daniel GHICULESCU³

¹ Polytechnic University of Bucharest, gabriela_marina.ene@upb.ro

² Polytechnic University of Bucharest, alexandra.cotofana95@gmail.com

³ Polytechnic University of Bucharest, daniel.ghiculescu@upb.ro

ABSTRACT: The paper deals with the development of a prototype modular equipment for electrochemical deburring to be used in case of small and medium size workpieces that can be machined just on the worktable of the equipment, but mainly in case of large parts, when the mobility and modular characteristics become of high weight because the machining takes place *in situ*. The main problems approached are anticipating and calculating the size, and the shape of the burrs, removing them evenly and creating a process and product that minimizes and controls the size of the burrs. Aspects concerning the conceptual and the detailed design, the simulations related to the primary current distribution using dedicated program COMSOL Multiphysics, which allows the control of the deburring process are presented. These issues are of the utmost importance for this stage of a prototype.

KEYWORDS: electrochemical deburring, modular equipment, finite element.

1. INTRODUCTION

Ulrich and Eppinger define new product development (NDP) as "a set of activities that begin with the perception of a market opportunity and end with the production, sale and delivery of the product." According to them, there are five main phases involved in creating and launching a new product, as presented in figure 1 [1].



Figure 1. Eppinger's product development process

Following the identification and selection of the opportunity on the market, according to the previously predefined methodology, it was found that the product that meets the most criteria of the matrix is the modular mobile equipment for electrochemical deburring. This product is mainly addressed to Romanian SMEs and nonconventional technology laboratories within the faculties. It is known that the budget of these enterprises is limited, so the product developed allows the use on existing equipment and can process a wide range of parts (figure 4, 5) and type dimensions.

2. PHENOMENOLOGY

Electrochemical deburring (ECD) is based on the phenomenon of electrolysis [2]. The synthesis of the

basic phenomena occurring during in the deburring process is presented in figure 2.

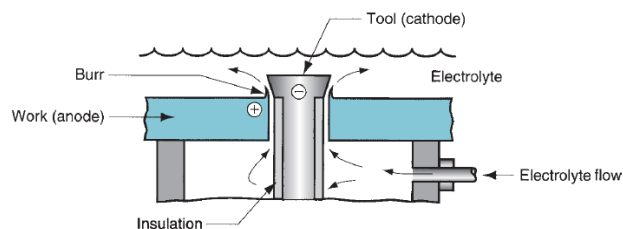

Figure 2. Basic phenomenology [2]

The primary and secondary current distribution are approached in order to keep control of the process. The primary current distribution accounts only for losses due to solution resistance, neglecting electrode kinetic and concentration-dependent effects. The charge transfer in the electrolyte is assumed to obey Ohm's law. There are two assumptions: first, the electrolyte is electroneutral, which cancels out the convective contribution to the current density and second, the composition variations in the electrolyte are negligible (it is homogeneous), which cancels out the diffusive contribution to the current density [5].

The secondary current distribution accounts for the effect of the electrode kinetics in addition to solution resistance. The assumptions about the electrolyte composition and behaviour are the same as for the primary current distribution, resulting in Ohm's law for electrolyte current. The difference between the primary and secondary current distributions consists in the description of the electrochemical reaction at the interface between an electrolyte and an electrode; it also refers to the fluid flow (electrolyte flow across the workpiece geometry).

3. APPLICATIONS OF ECM DEBURRING

Electrochemical deburring is used in various fields, from automotive to medical equipment (figure 3). Thus, the applicability of the procedure is one of interest.

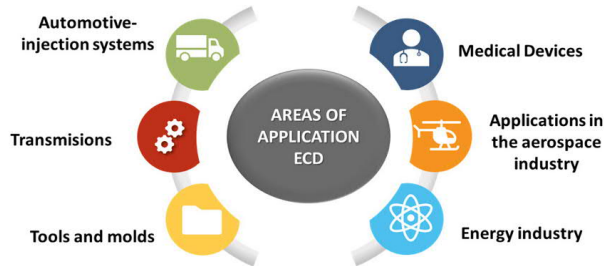

Figure 3. Areas of application for Electrochemical Deburring

The machining consists in removing the burrs that appeared as a result of the conventional machining, the material being taken by anodic dissolution. The workpiece (EP) is connected to the positive pole (anode +) of a direct current generator, and the tool (electrode) to the negative pole (cathode -) of the same source. In the space between the two electrodes, called the working gap, an electrolyte is recirculated at a predetermined pressure and speed [3].

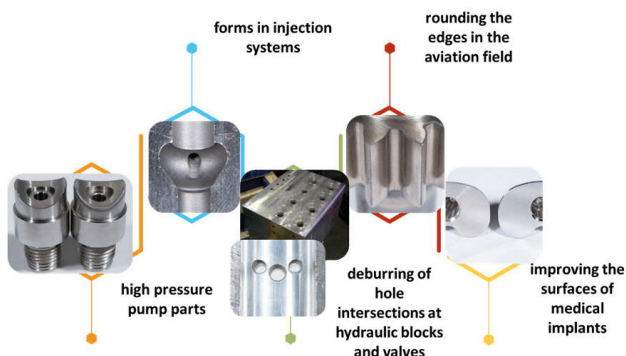

Figure 4. Types of parts processed by ECD

The main advantages of the ECM deburring are high machining rate; access of the inner surfaces, difficult to machine through conventional machining; bacterial decontamination and even radioactivity removal; no mechanical stress induced by machining as anodic dissolution of material is produced.

4. CONCEPTUAL DESIGN OF THE PROTOTYPE

Using TRIZ methods [4] and then evaluating the concepts according to the established criteria resulted in three partial concepts.

The main tools for resolving technical contradictions are the Contradiction Matrix [4], the 40 TRIZ Principles and the 39 Parameters.

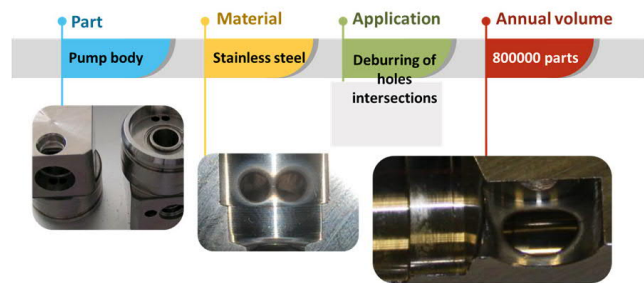

Figure 5. Case study: Pump body- deburring and rounding edges and intersections [3]

Other similar equipment from the state of the art are presented in figure 6.



Figure 6. Equipments for Electrochemical deburring available on the market [13], [14], [15], [16]

Analysing recent patents [8], [9], [10] it was decided to present three of them, relevant to the state of the art. Figure 7 a) shows the patent for an automatic and portable device for electrochemical deburring. The patent brings as a novelty the portability of the equipment, being a desired specification in the current product developed. Figure 7 b) shows a patent for equipment for deburring parts of TZM - molybdenum alloy with titanium, zirconium and carbon particles. The novelty is the impulse processing regime that leads to improvements in surface quality. The Australian patent shown in Figure 7 c) is for an electrode tool that can be used for both manual deburring and automated equipment.

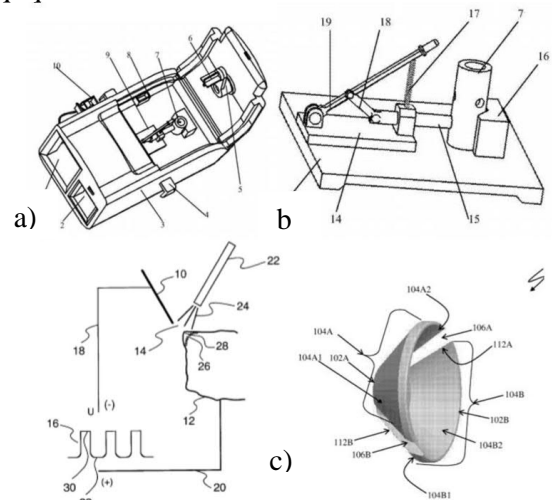

Figure 7. a) Patent CN105269093A [10], b) Patent USOO6139715A [9], c) Patent AU2016101408A4 [8]

• *Formulation of the technical contradictions*

Technical conflicts arise when an improvement of one feature of the system leads to a worsening of another feature of it. A technical conflict therefore involves two features of the system, as it follows:

Φ Reducing the weight of the deburring equipment decreases its strength over time.

Φ Increasing the complexity of the equipment decreases the ease of manufacture and ease of operation.

Φ Increasing the adaptability of the equipment decreases its manufacturability.

The contradiction matrix [4] is a tool for selecting the inventive principles used to solve a certain

contradiction. Altshuller stated that "an invention is the solution of a contradiction." Technical conflicts arise when an improvement of one feature of the system leads to a worsening of another feature of the system.

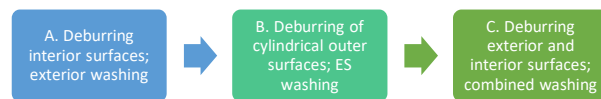

Following the selection of the optimal concept, C was the one that met optimally the conditions. The developed concept is composed of 5 distinct modules, as seen in figure 8.

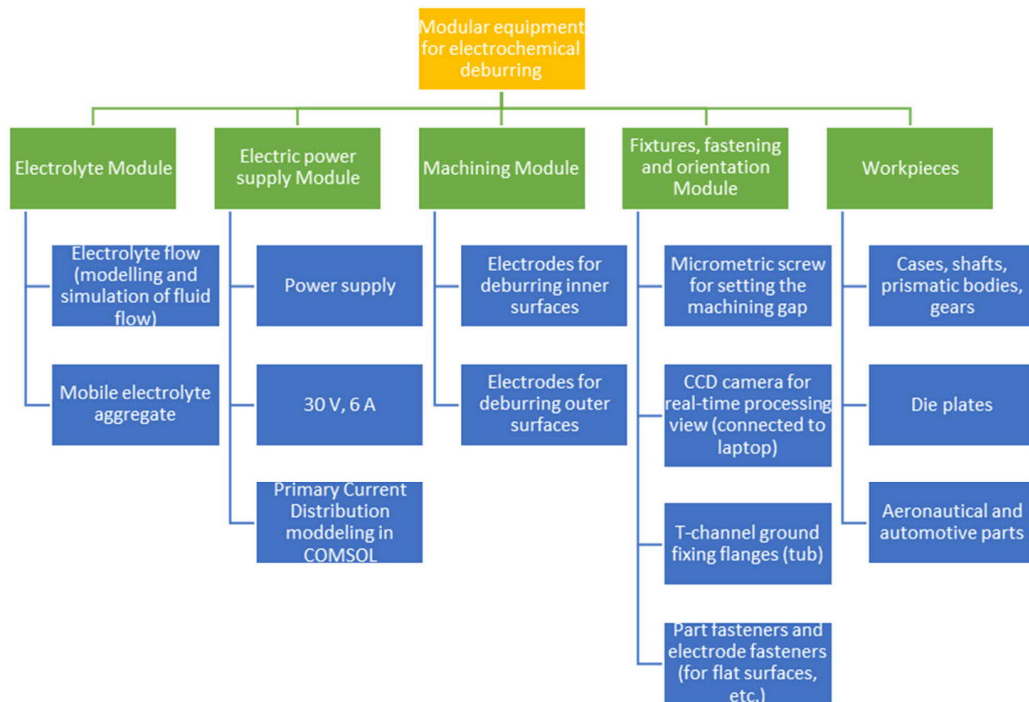

Figure 8. Equipment's modules

5. DETAILED DESIGN OF THE PROTOTYPE

Deburring equipment consists of (figure 9): 1-internal washing system, 2-tool electrode 1 and tool electrode assembly 2 (connected to the pole -), 3-hinges, 4-valves, 5-electrolyte basin, 6 -electrolyte recirculation hose, 7-EP inner wash hose, 8-outer wash hose, 9-AC source (provides 8-30 V voltage and 100 A deburring capacity), 10-wheel. 12-housing, 13-working tank, 14-T-channel magnetic table, 15-part fixing system, 16-tool holder assembly, 17-ES inner wash hose, 18-spherical joint, 19-micrometric screw, 20-tool electrode (3) (connected to the pole -), 21-cathode power cable, 22-anode power cable, 23-piece electrode (connected to the + pole), 24-door access. The electrolyte unit also has an electrolyte management system that filters the liquid, recirculates

it, and ensures a constant temperature and pH value and a flow within the limits imposed by the process.

The working environment is the aqueous NaCl solution, which can be changed with any electrolyte (NaNO₃, sodium silicate, K₂NO₃, etc.); the recommended concentration is between 14% and 20% and the processing gap is between 0,015 mm and 3 mm [1].

The adaptability element consists in changing the working head 3 with electrodes with the conjugate shape of the deburring surfaces.

The portability proposed for the concept involves the installation of various modules on equipment for electrochemical processing.

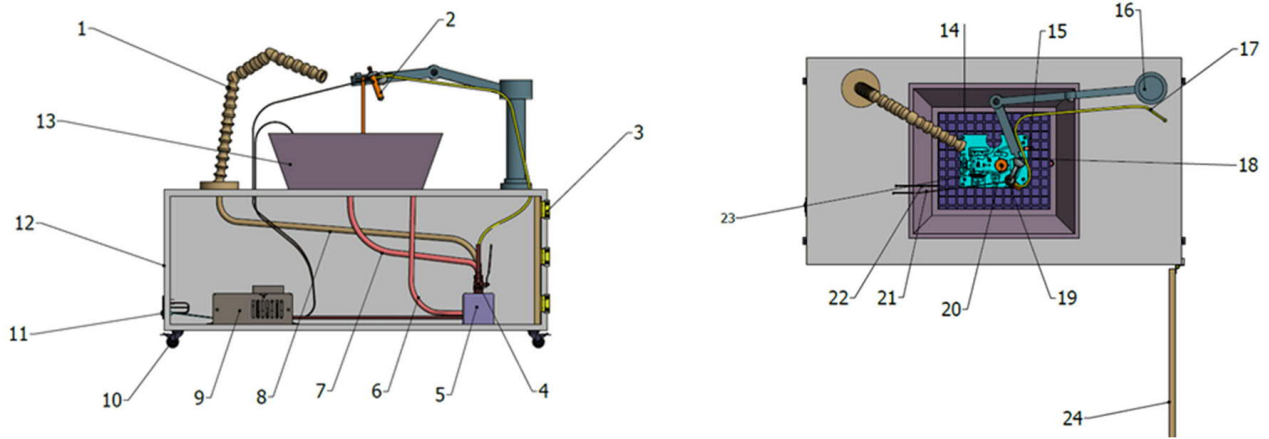

Figure 9. Modular Equipment's components

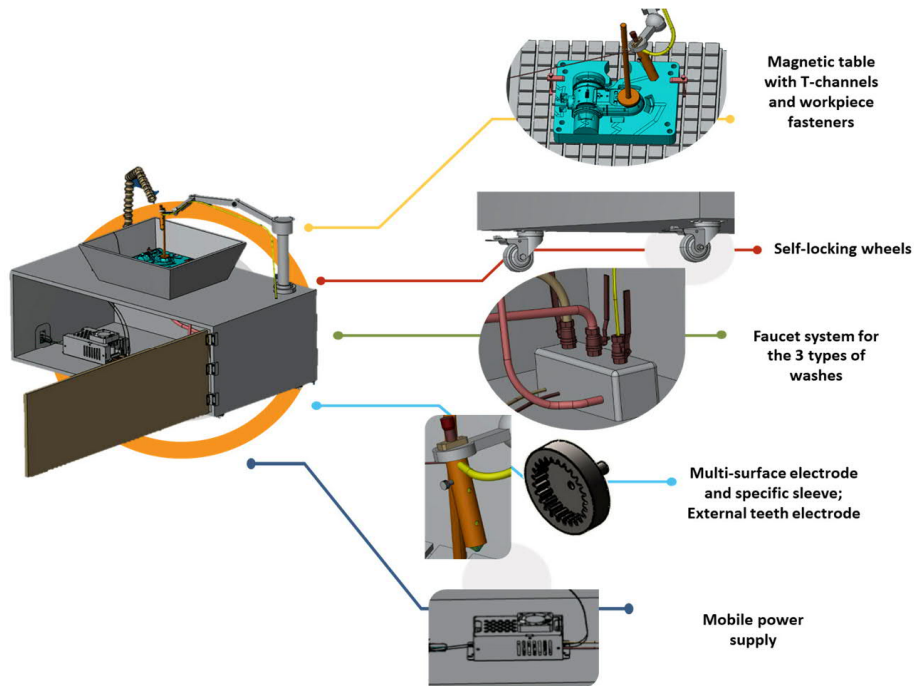
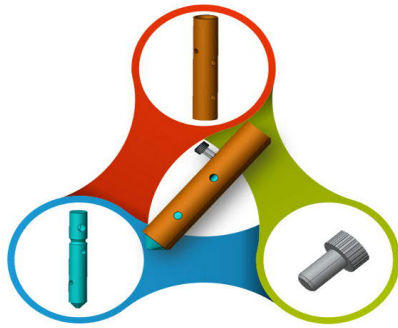

Figure 10. Modular equipment for electrochemical deburring-specifications

The machine table with T-channels is magnetic; this gives the device high adaptability. The fixing and positioning of the electrode-part is no longer in close contact with fastening and orientation elements such as positioning bushes, flanges, clamps, chucks, pins, nuts, screws, etc. Thus, the use of a magnetic table allows the processing of parts of different sizes and geometries. The table has the size of 800 mm x 650 mm. The wheels attached to the equipment allow its mobility, in order to ensure easy transport. In order to select the right materials for the construction of the equipment, it is necessary to consult the specialized manuals. Depending on the efforts that may occur during operation but also during assembly, the technological system provided (processing equipment), qualification of operators, storage space, tools, the material is chosen. The tool

electrode assembly (2) (figure 11) makes it possible to process several holes, using the same tool. In the case of machining a hole with an uninsulated cylindrical electrode, the lack of lateral insulation means that the material is removed continuously. Thus, a paraboloid shape will be obtained [1]. A PVC sleeve was designed as an insulating element. In addition to the role of insulator, it makes it possible to process the burrs resulting from the intersection of holes A, as well as the burrs resulting from the intersection of holes B. By rotating the screw, the sleeve can be rotated, thus revealing one of the holes. In the case shown below (figure 12), using the electrode with the sleeve in position 1 (figure 11) the resulting burrs can be machined at the intersection of holes A. If the electrode with the sleeve in position 2

(figure 11) is used, it machines the resulting burrs at the intersection of holes B.



a) Components of the electrode-tool assembly

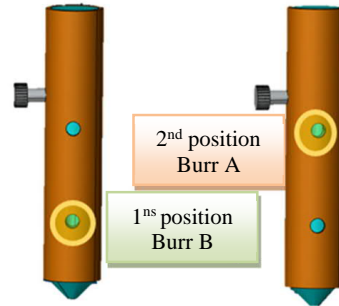

b) Positions of the electrode-tool assembly

Figure 11. Tool electrode assembly (2)

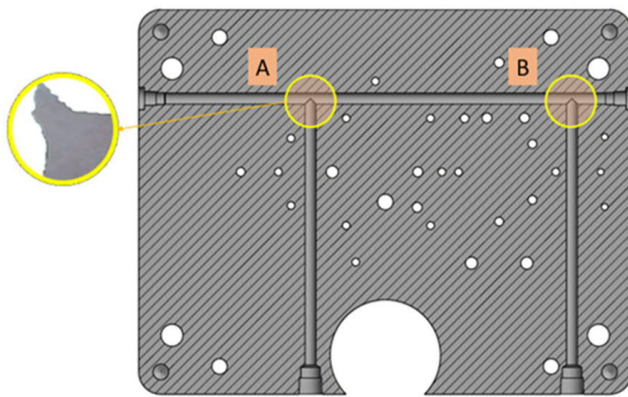

Figure 12. The intersection of holes on the workpiece



Figure 13. Fastening the processing module on large parts (hydraulic block)

At the same time, the equipment has the possibility for the processing module to be mounted on very large parts (die plates, hydraulic blocks, etc.) and the processing is performed differently than in the classic mode (the part is mounted on the table with T channels).

The machining device (figure 12) has the tool electrode integrated - with the sleeve presented above, the device being made of electro-neutral material to avoid unwanted anodic dissolution; the device is mounted on the deburring part, having the advantage that the operator does not have to transport the part between the processing stations (the parts having, by default, an unsuitable weight for a human operator).

6. MODELING AND SIMULATION OF THE PROCESS

This stage supposes two ways of the study: primary distribution of the current, resulting from specific geometry from the working zone, and secondary distribution of the current, related to uniform control of the electrolyte in the working gap. From the point

of view of the manufacture and testing of the developed equipment, CAD and CAE simulation programs were used. These software packages [7] allow the virtual construction and simulation of 3D, the results having a very small error compared to the results on real parts. The simulation allows the understanding of the operation of the equipment, allowing the innovation and the optimal design; testing in the virtual environment brings increased performance, being more efficient regarding the costs, than testing physical prototypes.

COMSOL Multiphysics software is a multidisciplinary platform that has in its composition modules that can be coupled or used singularly, highlighting all relevant physical effects.

Based on the above presented models, the simulation software of process with application of cylindrical tool has been developed. The input parameters for the simulation are as it follows:

- Shape of the machined surface;
- Electrode tool diameter;
- Electrical and kinematical parameters of the ECD process.

- Tool path.
- **Module: Electrochemistry**

The Electrochemistry module is part of the chemical simulation package; in its composition there are several sub-modules (Primary, secondary and tertiary current distribution, Corrosion). The Primary and Secondary Current Distribution sub-modules were considered to simulate the operation of the electrochemical deburring equipment. Thus, the algorithm behind the module has equations and boundary conditions related to ohmic losses.

• **Primary and Secondary Current Distribution**

The main current distribution [6] accounts only for losses due to the resistance of the solution, neglecting the kinetic and concentration-dependent effects of the electrode. The charge transfer to the electrolyte follows Ohm's law.

The current modelling and simulation intend to highlight the distribution of electricity intensity on the existing burrs on the part. Thus, a stationary study was chosen, i.e. it does not depend on time.

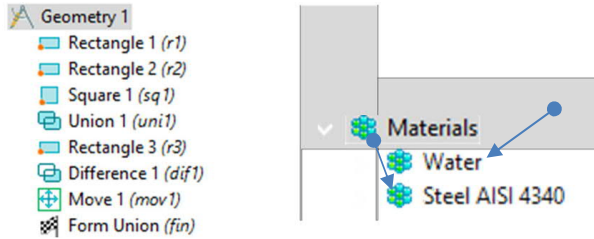

a) Geometry modelling and material for Primary Current Distribution

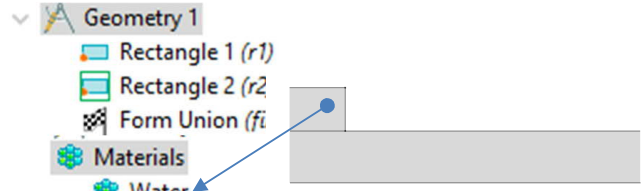

b) Geometry modelling and material for Secondary Current Distribution

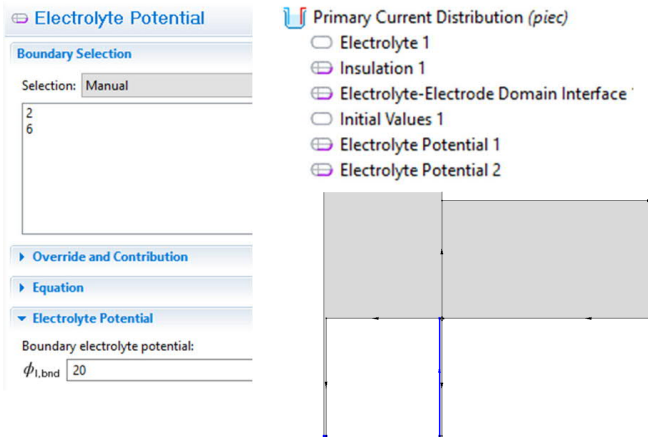

c) Electrochemistry Module: Boundary Condition (Primary Current Distribution)

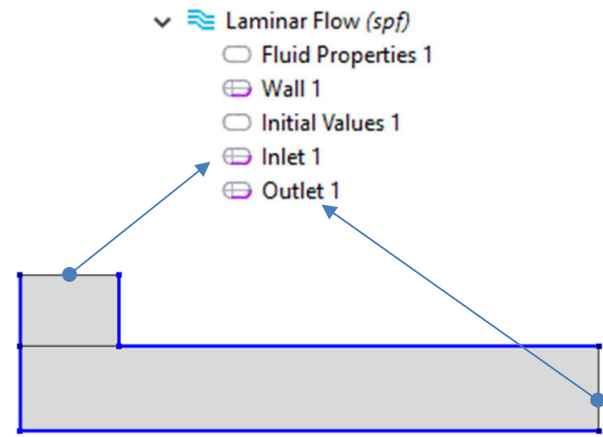

d) Electrochemistry Module: Boundary Condition (Primary Current Distribution, $p_i=2\text{MPa}$, $p_o=0,1\text{MPa}$)

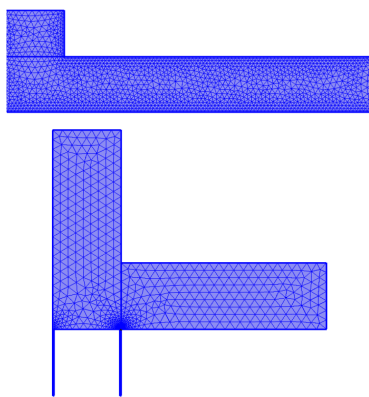

e) Meshing network

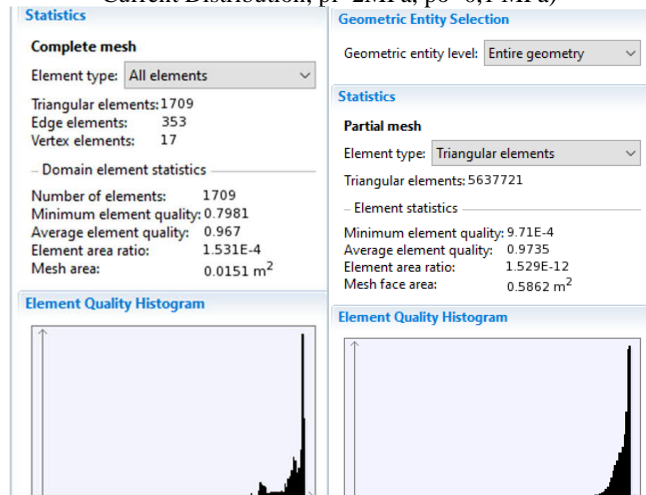

f) Statistics for meshing (Average element quality)

Figure 14. Modelling stages for the Primary and Secondary Current Distribution

The method of simulation concerns the following stages: model parametrization, creating the geometry, applying the material, setting the boundary conditions, meshing and model solving set-up.

The simulation has as input the geometry of an intersection of holes (figure 14 a, b), located on the surface of an active plate from a plastic injection mold, and a burr resulting from previous conventional machining of size 0.5 mm, the machining gap is set to 1 mm. The active part of the deburring electrode was also modelled, the rest being isolated with the sleeve shown above. The conductivity values of the electrolyte and the electrode were specified, the limit condition for this module (electrolyte potential 20 V-figure 14 c), remaining for the program to determine the electrically isolated areas of the modelled geometry.

From an engineering standpoint, it is important to predict and understand how the fluid (electrolyte in case of ECM deburring - as presented in simulation figure 14 d) flows inside a part with complex geometry, such as a mold. The mold has two parts: the core and the cavity and both have plenty of holes in different positions (some of them are intersected). The perpendicular holes were machined through cutting and the burr is difficult to be taken out.

As concerning appropriate boundary conditions, which defines the problem, in order to get the solution of that specific problem, an Inlet and Outlet for the electrolyte were defined and completed the sections with velocity/pressure. The inlet corresponds to

cavity mold's entrance for the cooling holes and the outlet for the value for pressure was 1-2 MPa.

When modelling the second current distribution, the material setting is divided in two parts: the electrolyte path is associated with water and the burr with steel (figure 14 b). The meshing process is a complex one, defined with physics-controlled mesh and a normal element size.

In figure 14 e-f, it is presented a statistics of the meshing network; the average element quality is 96.7% and 97.35%, for both cases (left, right); the quality of the elements is very good, using the shape of the elements imposed by the physics module.

7. RESULTS AND DISCUSSION

After applying the discretization with finite elements on the surface of the model appear in the form of arrows the direction of current movement. The part of the burr that is removed by electrochemical processing has the maximum value of current, as expected. In order to remove the burrs, it is needed to have a high inlet pressure correlated with a low outlet pressure, as the Secondary Current Distribution simulation shows.

The workpiece geometry influences the electrolyte flow and the removing process of the burrs. The pressure lost takes place mainly into the corners of the geometry. The optimum pressure found for electrolyte inlet was 2 MPa and for the outlet 0.1 MPa (figure 15) in order to obtain a deburring for the crossed holes machined on the cavity mold.

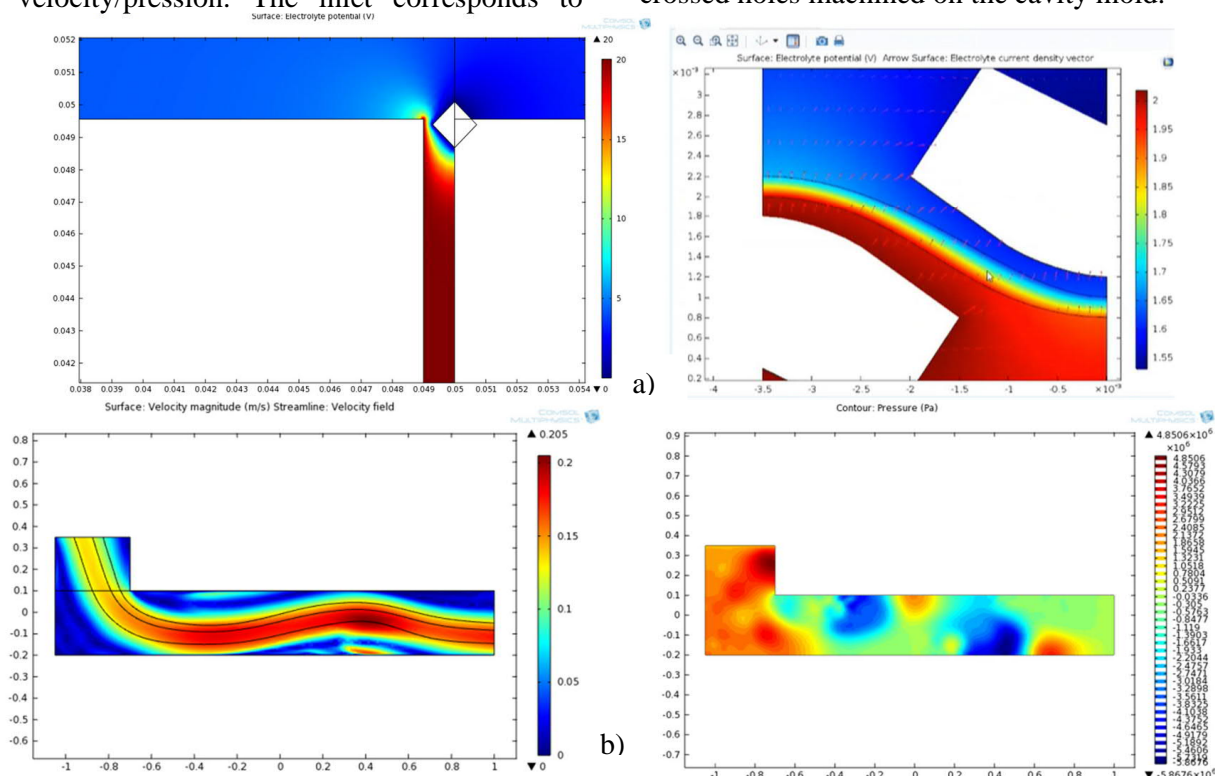

Figure 15. a) COMSOL captures for an intersection of holes and a gap of 1 mm, burr size max. 0,5 mm; insulated electrode with sleeve; b) Velocity and Pressure diagram for electrolyte with inlet pression 2 MPa and outlet pression 0.1 MPa (with streamlines)

8. CONCLUSIONS

The modular equipment for electrochemical deburring has passed the design phase and it is in the evaluation phase using CAD-CAE tools. Some working parameters were established, which will be confirmed through testing.

The contributions to the resulting concept in the strategic marketing chapter have undergone major improvements, with elements that make an important contribution to the portability of the device and its flexibility in terms of processed surfaces.

The developed product is a modular one, so that parts of various sizes and configurations can be processed only by adapting the electrode to the geometry of the workpiece and using merely the independent modules.

The evaluation of the product can be done in the COMSOL simulation programs for other electrode shape and dimensional variations (varying the electrically insulated part), as further researches.

9. REFERENCES

1. *** Product Design and Development-Eppinger &Ulrich, available at <https://www.pdd-resources.net/> (accessed 10.05.2020)
2. *** Electrochemical deburring, available at <https://me-mechanicalengineering.com/electrochemical-deburring-and-grinding/> (accessed 09.04.2020)
3. Muhammed Kör -MB Trading - Possibilities of electrochemical processing (Brochure STOBA)
4. Marinescu N.I. et al., *Tratat de Tehnologii Neconvenționale. Vol.4, Prelucrarea prin eroziune electrochimică*. Printech, ISBN (13) 978-973-718-613-3, Bucharest, 2006.
5. ***TRIZ Method available at <https://en.wikipedia.org/wiki/TRIZ>, (accessed 30.05.2020)
6. *** Basic phenomena occurring during in the deburring process, available at <https://me-mechanicalengineering.com/electrochemical-deburring-and-grinding/> (accessed 21.05.2020)
7. *** Current distribution interface use, available at <https://www.comsol.com/blogs/current-distribution-interface-use/> (accessed 30.05.2020)
8. *** COMSOL Electrochemistry Module, available at <https://www.comsol.com/electrochemistry-module> (accessed 23.05.2020)
9. Chetan Prabhakar PURAV, Deburring tool head, Australia, AU 2016101408 A4, 2016
10. Bin Wei, Clifton Park for General Electric Company, Electrochemical Deburring or Radiusing, USA, US OO6139715 A, 2000
11. Li Jian Zhu Xunpeng Guo Yanling Yuan Weijie Portable and automatic electrochemical deburring device, China, CN105269093A, 2014
12. *** Electrochemical deburring (ECM) available at <https://extrudehone.com/electrochemical-deburring-ecm>, accessed 09.01.2019
13. *** ECM Deburring equipment Sermatec, available at <http://www.sermatec.com/en-223-home.html> (accessed 09.05.2020)
14. *** ECM Deburring equipment EMAG, available at <https://www.emag.com/technologies/pecm.html>, (accessed 09.05.2019)
15. *** ECM Deburring equipment Extrude Hone, available at <https://extrudehone.com/products/electrochemical-machining-ecm> (accessed 09.05.2020)
16. *** ECM Deburring equipment MetaTECH, available at <http://www.metatechind.com/html/ecm.html>, (accessed 09.05.2019)