

# COMPARATIVE STUDY TEMPER AND COOLING IN TWO AREAS OF A CYLINDRICAL USING VARIOUS NUMERICAL MODELING WITH ELTA

Burca Adrian<sup>1</sup>, Tocuț Dănuț Pavel<sup>2</sup>, Tripe Vidican Călin<sup>3</sup> and Pater Sorin<sup>4</sup>

<sup>1</sup> University of Oradea, Faculty of Electrotechnics and Informatics, [aburca@uoradea.ro](mailto:aburca@uoradea.ro)

<sup>2</sup> University of Oradea, Faculty of Management and Technological Engineering, Mechatronic Department, [tocutpd@yahoo.com](mailto:tocutpd@yahoo.com)

<sup>3</sup> University of Oradea, Faculty of Management and Technological Engineering, Mechatronic Department 3, [tripetrophy@yahoo.com](mailto:tripetrophy@yahoo.com)

<sup>4</sup> University of Oradea, Faculty of Management and Technological Engineering, Mechatronic Department, [spater@uoradea.ro](mailto:spater@uoradea.ro)

**ABSTRACT:** The paper proposes an analysis of the heat treatment process (hardening, tempering) of a cylindrical surface with the help of software ELTA. Numerical modelling in the two cases shown, for cooling, the work piece jet of water and compressed air, will help to achieve a better comparison / efficient heating process by means of eddy currents, all at once is underlined the role of specialized software of the design and construction of a induction heating, because it allows us to choose the best solution for the induction heating system.

**KEYWORDS:** 5 - 6 induction, electromagnetic field, numerical simulation, temperature, cylindrical

## 1. INTRODUCTION

HEATING systems by induction using the phenomenon of electromagnetic induction discovered by Michael Faraday (1831), a phenomenon in which electric current is induced in a circuit in a conductive material near, a phenomenon, which is based on electric field, and a magnetic alternating in time [1].

Faraday's discovery led to the development of electric motors, transformers, wireless communication, devices, etc.

Inductive heating is used successfully in industrial applications, in private homes, even medical. This type of heating has grown with the advent of power electronic devices [2].

Inductive heating systems compared to systems using hydrocarbons are more effective because they are faster and cleaner. The variable magnetic field lines penetrate into the piece-varying magnetic field by means of the voltage, which can create an electrical current depending on the shape and electrical characteristics of the part to be machined [3].

These currents are swirling currents call; it dissipates energy and generates heat conductive material of the piece being manufactured.

Induction heating has a wide range of applications, but the most used are industrial, although in recent years has greatly expanded and applications endeavour (domestic) such sons' hobs and boilers for hot water and heat [4]. In industry, the most well-known applications are soldering, heat treatment (hardening, heating in volume), melting,

etc. graphitized. Among the applications listed above are the most common heat treatments (quenching areas) [5].

Electromagnetic induction heating involves three physical phenomena suggestive: inductive energy transfer-piece, transforming electrical energy into heat, Joule effect, heat transfer across the table by heat conduction.

The induction heating heat develops in the work piece without the need for a transmission agent and without the use of direct contact (physically).

This heating method ensures high productivity, high accuracy, can be easily automated and controlled. Other favourable aspects are such a small space for installation, clean working conditions and low noise and integration into an automated production line [6].

## 2. PRESENTATION AND NUMERICAL DATA ENTRY APPLICATION PROBLEM

The following is a brief overview of the software ELTA, with which the process is performed simulation of a surface hardening. It was used this software because this software is made for industry, it has a very easy and friendly interface [7]. Elta gives very accurate results, showing a real help for those dealing with the design of heating by induction, but also for users (beneficiaries) installations [8].

ELTA provides a very fast and accurate simulation of the electromagnetic field and heat using a one-dimensional approach (1D). It is able to simulate induction systems for cylindrical or rectangular pieces, magnetic or non-magnetic. It allows the use

of field concentrators for the lines, and the cooling of the treated part of the inductor (with compressed air or water). It is useful for finding an optimal response in the meantime, temperature and power [9].

Although it is a soft 1D, it takes into account the finite lengths for the coil and the work piece, using an analytical method called " the total flux" This method is based on the composition of a magnetic circuit of substitution for an "inductor - work piece". It can be used in combination with other software, which are 2D or 3D graphics [10]. In order to achieve the numerical modelling of the process of the electromagnetic induction were needed a number of data prior to data entry: the geometrical dimensions of the work piece (material properties), the geometrical dimensions of the system inductor - piece - cooling system, the geometrical dimensions and the material properties the inductor, the geometric dimensions of the network (short supply bars of the inductor), the speed of travel of the work piece through the inductor, but also by the cooling system, data on the cooling system and the flow rate of water through the inductor, the frequency used for heating (100KHz). You can choose the desired accuracy for the calculations by application from Normal, High or Custom [10].

In the picture below Fig. 1. shows the window for defining piece and are introduced geometrical and material data piece.

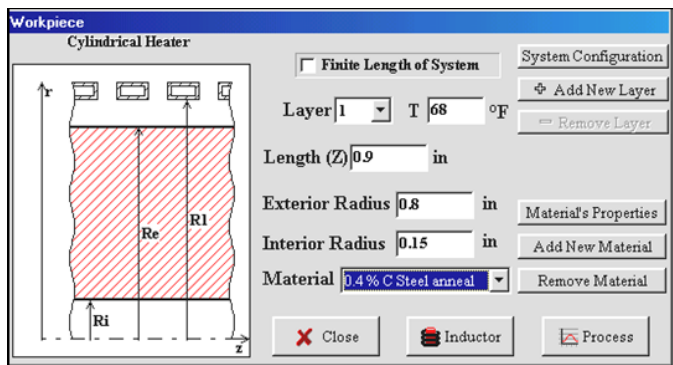

Figure. 1. Definition of the part [10]

The window defining the inductor Fig. 2. the inner radius of the inductor is specified, the number of turns, the material is copper (as copper is usually inductor). The number of turns is chosen depending on the length or piece is moving.

The simulations were made for an induction heating process of several phases, heating, cooling step, etc. For each heating or cooling stage the residence time must be introduced. The cooling of the work piece after heat treatment (heating) is performed in two

ways: cooling by natural or controlled cooling water or compressed air jet.

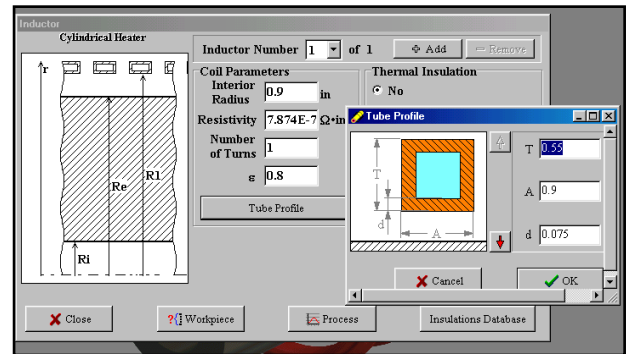

Figure. 2. Defining the inductor [10]

After finish the calculations, the application stores the results in the form of a report, which are provided important information about the temperature of the piece of the inductor voltage, current density, efficiency, the impedance of the inductor, the reactive power, frequency, etc. The results are easy to analyze, as they are provided in the form of graphs.

### 3. NUMERICAL MODELING OF TWO PROPOSED SITUATIONS

Numerical modelling of a piece with the cylindrical surface using the heated cooling surface (view surface hardening) with both methods that can be used in the application ELTA (cooling water and compressed air).

In the Fig. 3. shows the part which is to be heat treated. The piece is made of mild steel OL45. The area subjected to heat treatment, hardening, is on the outside of the track and has a length of 28.2 mm.

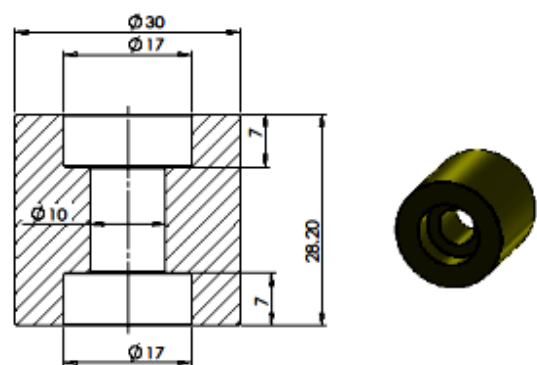

Figure. 3. The cylindrical piece (1D and 2D)

It is used a system that works in two stages: the first stage heating is performed, and the second step is carried out by cooling the piece with water or air jet according to Fig. 4.

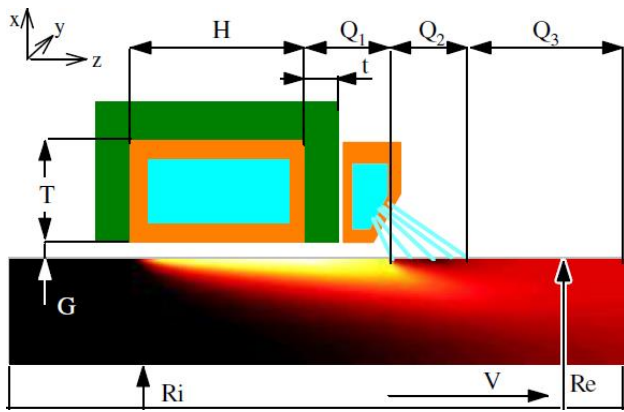

Figure 4. Hardening System configuration [10]

The meaning of the notations of Fig. 4. is shown in the following values with concrete in the illustrated case:

- 1) Re - 15 mm - radius of the work piece to be hardened;
- 2) Ri - 5 / 8,5 mm - inner radius of the part (Re-Ri are the wall thickness);
- 3) G - 5 mm - distance between the coil and the work piece (gap);
- 4) Q1 - 0 mm - distance between the cooling system and inductor;
- 5) Q2 - 10 mm - the cooling zone (the distance that the water falls);
- 6) Q3 - 50 mm - the water that fell;
- 7) T - 10 mm - the height of the spiral inductor;
- 8) t - 10 mm - the thickness of the hub;
- 9) V - 5 mm / sec - the speed of the piece;
- 10) H - 7 mm - the overall length of the inductor.

It was choosing a rectangular profile copper coil having a height **T** (10 mm) **width** (7 mm) and a thickness **d** (1.5 mm), as shown in Fig. 3. The flights will be cooled with water, the same water that will cool and the work piece. For inductor was chosen a single turn. As mention the significant properties of the copper resistivity ( $\rho_{Cu} = 2 \cdot 10^{-6} \Omega \cdot cm$ ) and emissivity ( $\varepsilon = 0.8$ ).

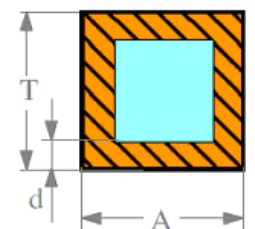

Figure 5. The geometric shape of the inductor coil [10]

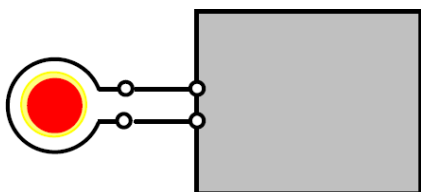

Figure 6. Heating system scheme [10]

Fig. 6. is a schematic diagram of the heating system, where it is noted that the power of the transformer is made by means of rails? In turn these power rails must be designed and will take into account the following parameters:

- 1) h (3 mm) - the distance between the rails (insulation);
- 2) L (100 mm) - length of the rails (distance between the inductor and transformer);
- 3) A (10 mm) - the height;
- 4) T (2 mm) - thickness of the rail.

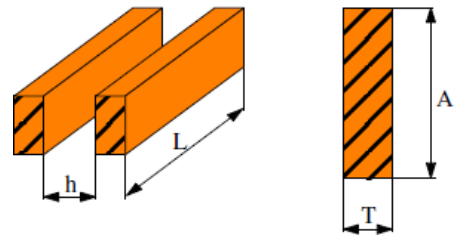

Figure 7. Power rails of the inductor [10]

Original quality parts will have a temperature of 20°C. It chose the operating frequency  $f = 100$  kHz and the inductor current  $I = 180$  A, the voltage across the inductor  $V = 65$  V. It took into account a coefficient of convection (heat transfer surface)  $\alpha = 20$ . After quenching, the first step follow a second step, the cooling of the work piece.

Cooling is done by running water through the cooling water velocity is 2 m/s. Cooling can be done with the water jet, air jet, salt, or in some cases the piece is cooled naturally.

Following the simulation were obtained some results (for cooling water):

*Processing:*

Frequency ( $f$ ) =  $1 \cdot 10005$  Hz.

Power ( $P$ ) = 2500 W;

Velocity ( $V$ ) = 0.5 cm/s;

External Cooling Media = Water Shower 2 m/s;

Internal Cooling Media ( $Q_2$ ) = Water Shower 2 m/s;

Coupling Gap ( $G$ ) = 0.3 cm;

Heating Zone ( $H$ ) = 1 cm;

Cooling Zone ( $Q_1$ ) = 0.4 cm;

Quenching Zone ( $Q_2$ ) = 2 cm;

Cooling Zone ( $Q_3$ ) = 5 cm.

*Electrical Parameters: Coil Head*

Electrical Efficiency = 0.74598;

Total Efficiency = 0.74144;

Power Factor = 0.21356;

Inductor Current = 183.1 A;

Inductor Voltage = 65.108 V;

Inductor Power = 2500 W.

*Coil Cooling Parameters (the cooling of inductor):*

Input Temperature = 20°C;  
 Output Temperature = 50°C.  
 Water Flow Rate = 3.063 lt/min;  
 Sections Number =1;  
 Pressure Drop = 0.00062363MPa.

The following results are presented in graphical form obtained from simulation.

Fig. 8. Shows the tri-dimensional form the link between the temperature range and the timepiece.

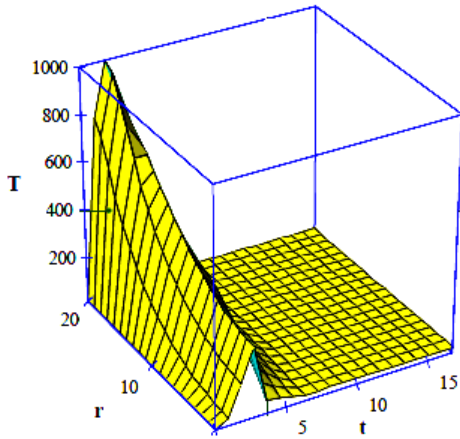

Figure 8. 3D representation of the relationship between T, r and t

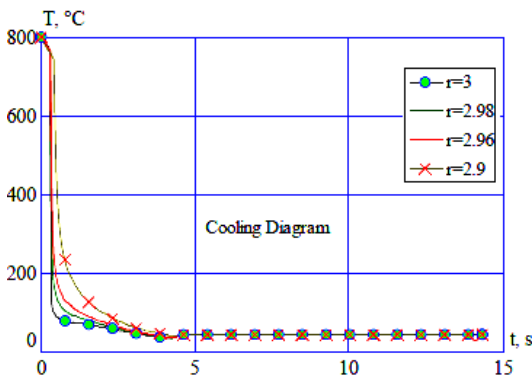

Figure 9. Cooling diagram

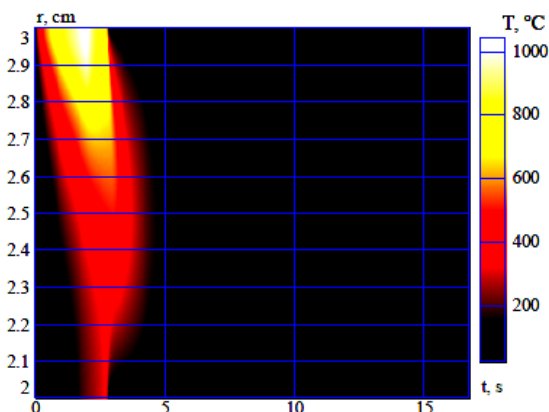

Figure 10. The temperature of the piece

In the Fig. 10. was observed the depth of temperature penetration on the piece.

The penetration depth of the current in the surface layer, and finally hardened layer depth of the induced current depends on the frequency and is determined by the relationship:

$$\delta = 5,03 \cdot 10^3 \sqrt{\frac{\rho}{\mu \cdot f}} \text{ [cm]} \quad (1)$$

where:  $\rho$  – the resistivity of the metallic material,  $\Omega \cdot \text{cm}$ ;  $\mu$  – the relative magnetic permeability of the metallic material;  $f$  – flow rate, Hz [10].

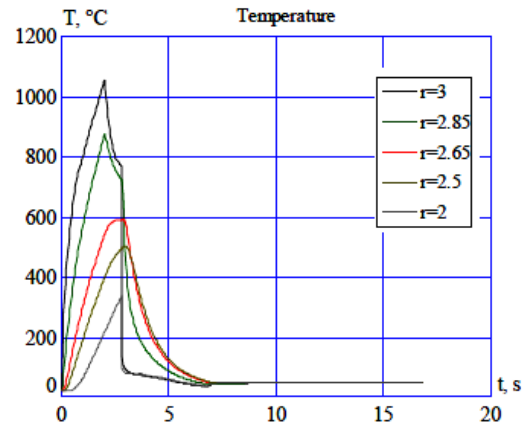

Figure 11. Temperature versus time

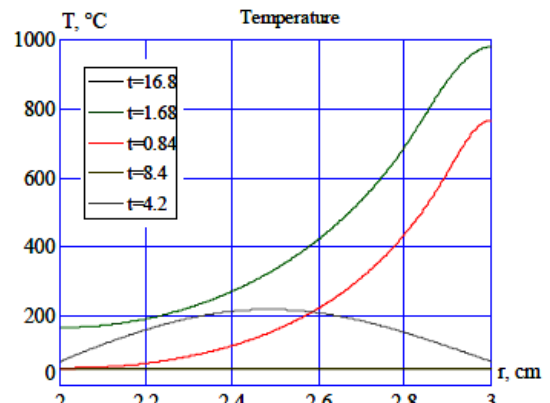

Figure 12. Temperature versus range

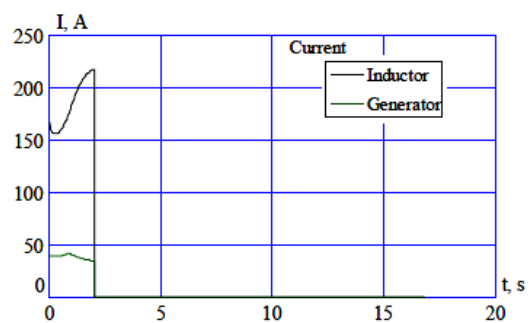

Figure 13. Inductor current

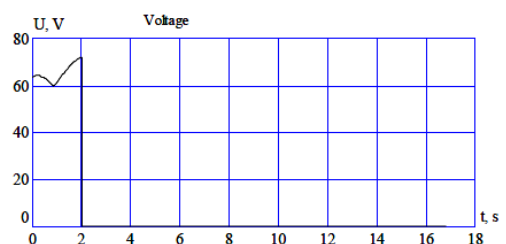

Figure 14. The voltage across the inductor

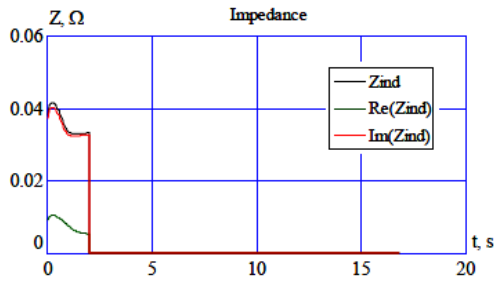

Figure 15. Inductor impedance

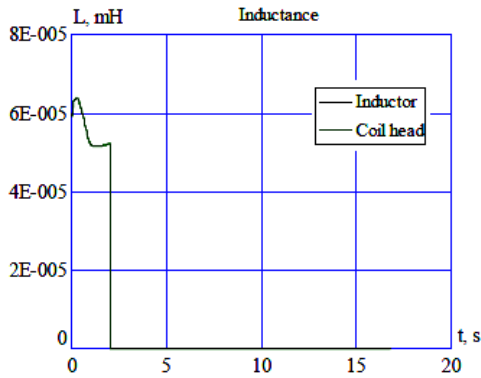

Figure 16. Inductor inductance

They are presented the obtained data for using the cooling system with compressed air is the inductor is cooled with water. They have used the same input data for the piece, inductor, only the cooling of the heated surface was carried out by jet air.

Processing: Frequency ( $f$ ) = 100kHz;  
 Power ( $P$ ) = 2500W; Velocity ( $V$ ) = 0.5 cm/s.  
 External Cooling Media = Air Compressed 30 m/s.  
 Internal Cooling Media ( $Q_2$ )= Water Shower 2 m/s.

Coupling Gap ( $G$ ) = 0.3 cm.

Heating Zone ( $H$ ) = 1 cm; Cooling Zone ( $Q_1$ ) = 0.4 cm.

Quenching Zone ( $Q_2$ ) = 2 cm; Cooling Zone ( $Q_3$ ) = 5 cm.

Electrical Parameters: Coil Head

Electrical Efficiency = 0.74598; Total Efficiency = 0.74144; Power Factor = 0.21356 .

Inductor Current = 183.1 A; Inductor Voltage = 65.108 V.

Inductor Power = 2500W.

Coil Cooling Parameters (the cooling of inductor)

Input Temperature = 20°C; Output Temperature = 50°C.

Water Flow Rate = 3.063 It/min; Sections Number = 1; Pressure Drop = 0.00062363 MPa.

Fig. 17. shows in three-dimensional form the link between the temperature ,range of the piece and time, where compared to the Fig. 8. it can be seen how the temperature after cooling the piece is higher

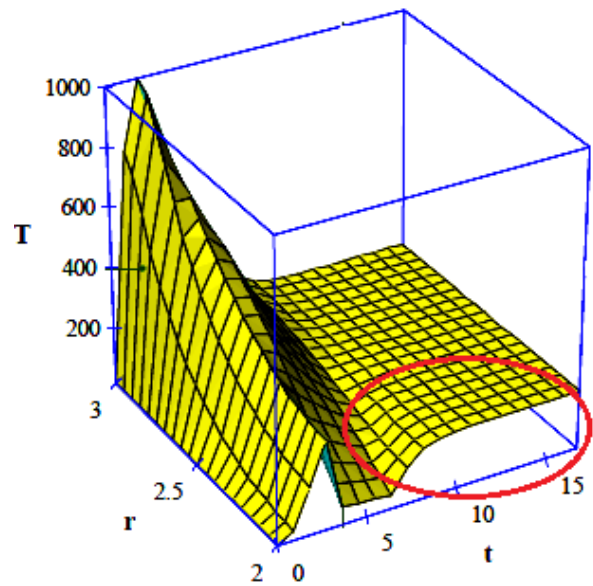

Figure 17. 3D representation of the relationship between T, r and t

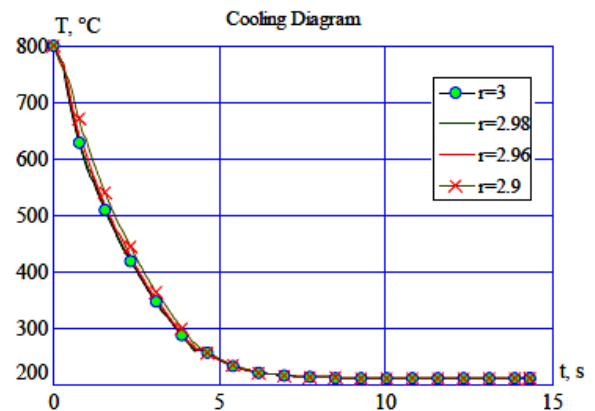

Figure 18. Cooling diagram

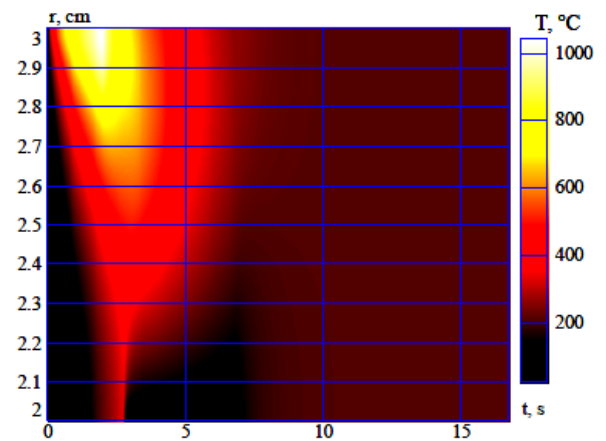

Figure 19. The temperature inside the piece

Comparison of the two sets of results aimed at finding the most efficient cooling system of heating work piece.

As can be seen in graphs (diagrams), the most effective cooling method was the cooling water jet.

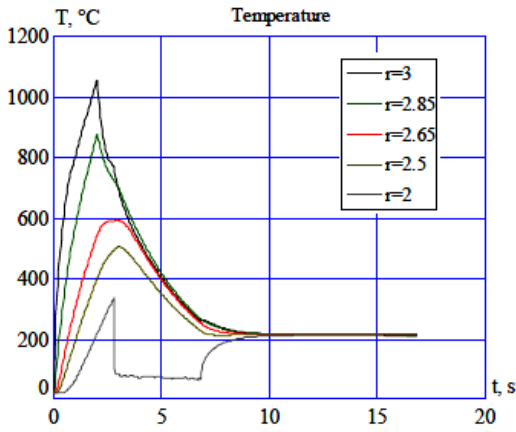

Figure 20. Temperature versus time

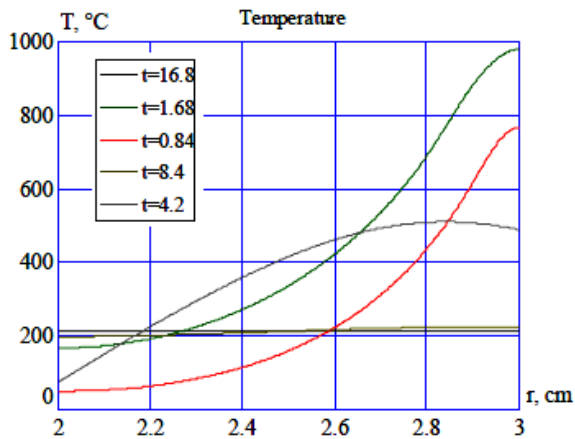

Figure 21. Temperature versus range

#### 4. CONCLUSION

Electromagnetic induction heating allows us to achieve high power density, which leads to significant reduction of heat loss (in part). This property makes induction heating very effective. From the description above results, it's seen that the part of the tempering temperature reaches  $1200^{\circ}\text{C}$ , in a period of 2-3 seconds, after starting the cooling of the work piece. Also the treatment process of the surface of the work piece, presented in this paper, it takes less than 15 seconds, during which the work piece is cooled with water, which leads to the possibility of implementing the system in an automated production line.

From the graphs comparing temperature distribution according to time and the length of work piece, it can be seen that the cooling water is more effective in comparison with the cooling air. Another advantage of using the cooling water is the cost; the cooling air is more expensive in economic terms.

The hardening / tempering surfaces is made for a better resistance to mechanical wear of the work piece.

The thermal treatment of the surfaces (hardening, tempering) is one of the most important applications

of inductive heating. With programs for numerical modeling can simulate coupled electromagnetic and thermal processes , noticing very fair the characteristics of the installation. Using ELTA 1D software greatly simplifies the design and implementation of heating systems using eddy currents because of the short time necessary to achieve the heating system with numerical methods . Numerical modeling offers to the specialist solutions to be able to choose the most optimal for the desired process.

#### REFERENCES

1. Oscar Lucia , ''Introduction to the Special Section on Induction Heating Systems'', IEEE transactions on industrial electronics, vol. 61, no. 5, may 2014Book of SolidWorks2013 Software, 2013.
2. A. Burca , ''Analiza sistemelor electrotermice inductive echipate cu invertoare de înaltă frecvență'', ISBN 978-606-10-1830-7, Editura Universității din Oradea, 181 pag, 2016.
3. P. A. Hassell (Hassell Associates), Nicholas V. Ross (Ajax Magnethermic Corporation), ''Induction Heat Treating of Steel, ASM Handbook'', Volume 4: Heat Treating, ASM Handbook Committee, p 164-202, DOI: 10.1361/asmhba0001153
4. N.D.Trip, A. Burca, T. Leuca, J. Dudrik, ''Considerations on the Analysis of an Induction Heating System'', International Symposium on Electronics and Telecommunications ETC 2014 Eleventh Edition, Timișoara, November 14-15, 2014, manifestare IEEE.
5. A. Burca, N.D. Trip, T. Leuca, ''Considerations on the Design of a Low Power Induction Heating System'', International Symposium of Fundamentals of Electrical Engineering 2014, Publication year: 2014, Bucharest, Romania, IEEE Conference Publication.
6. D. Comșa, ''Instalații electrotermice industriale'', vol II, București: Editura Tehnică, 1986.
7. V. Nemkov, *Role of Computer Simulation in Induction Heating Techniques*, Padua, Italy: Proceedings of the International Induction Heating Seminar, 1998, p. 301 – 309.
8. N. Nemkov, V. Demidovich, *Theory and Calculation of Induction Heating Devices*, Leningrad: Energoatomizdat, 1988.
9. <http://www.nsgsoft.com>.
10. ELTA At A Glance Manual