

THEORETICAL CONSIDERATION ON THE ABRASIVE WATER-MIXING CHAMBER MADE BY THE PLA MATERIAL WITH 3D PRINTING PROCESS BY FDM TYPE

Mircea Dorin Vasilescu ¹

¹ Politehnica University Timisoara, mircea.vasilescu@upt.ro

ABSTRACT: Made functional prototype with 3D printing technology is an important part to reduce the weight of the inertial force in CNC abrasive water jet machine. 3D printing by FDM deposit of thermoplastic material in layers it is relative new and modern process. The main advantage of 3D printing is that it is possible to made complex construction parts where difficult of the assembly or processing of the parts is not necessary, but at the same time, the assurance of positioning and precision are ensured directly by the technological printing process. The process applied for production of non-metallic or metallic particles in suspension for made parts. An experiment employing PETG material used for the generated of a mixing chamber for abrasive water jet installation. The generation parameters considered the roughness of the material on the abrasive surface contact surface for a thickness of 0.4 mm of printed wire and an infill of 0.1 mm for the layer. The construction of the mixing chamber is different from the usual existing mixing chamber on processing installation. This to optimize both the mixture of the abrasive and particles with water, but also to distribute equal the particles of abrasive material on the periphery of the active jet in the working installation. In the process of generating the mixing chamber, different material densities used to optimize the mechanical strength of areas where mechanical or hydraulic contact stresses occur. Future research directed towards to fabrication of the mixing chamber with metallic particles embedded in the plastic mass of the type PETG, ABS or PC.

KEYWORDS: 3D printing; fabrication parts; dimension gear, PLA material, FDM printing;

1. INTRODUCTION

Designing an experimental component model is an important step in investigating a process. Such concepts generated by the qualitative problems of the processing process, those related to the cost of processing or those due to the technological processes of generation. 3D print generation technologies provide complex and complicated assemblies in the form to generate in a form of a single element that obtained by generating the element with the geometric shape imposed by the experimental process to be achieved. The process of generating such an object ensured by 3D printing technology that allows the model to be made directly after generating the digital parts in space. The 3D printing process considered in this experiment is the thermal plasticization of the material by deposition of material and not as in the traditional processing processes by removing the material in the form of chips or energetic activation with locally concentrated energies such as beams or radiation.

The object manufactured by FDM process used to made full-scale prototype, tooling application and post-production part customization [1].

In the field of abrasive waterjet processing equipment, most of the materials are made of steel or aluminium obtained by casting or plastic deformation, followed by traditional machining processes by cutting and heat treatment where

required. These machining processes are expensive in terms of manufacturing costs and generate themselves and the processes of energy pollution processing due to both the large amount of energy that is technologically required to be used in the above-mentioned thermal processes, but and the particles in suspension on demand generates them during the melting or mechanical machining processes by rectification. From the above observations, replacing parts or assemblies with others obtained by less polluting or less energy-consuming processes used in their process is more than indicate and recommended to used. At the same time, in the research process or in studying the phenomena with the students, the consumption of energy resources is decisive and can ensure both the reduction of research costs and the transfer of better information about the process of study studied.

Another important element is the energy used to generate the abrasive jet. Because this most installations use the abrasive introduction into the mixing chamber on one side through a circular hole positioned perpendicularly to the direction of the abrasive jet generation and using the absorption phenomenon, high pressures are required to achieve the energy transfer from the kinetic energy of water to that of the particle that provides erosion.

From the studies carried out and as can be seen from the analysis of the mixing chamber used to generate

the abrasive jet (Figure 1.), the wearing appears more accentuated to the part of the output of the abrasive that is pushed by the water jet to the edge of the intersection edge between the construction cylinders. Price for 1 piece is 100 to 120 USD.



Figure 1. Mixing chamber construction [1,]

Obtaining the sample for the mixing chamber accomplished by wire erosion cutting of such a chamber following the diametrically directed water jetting direction.

One of the major problems as could be identified from the practical processing is related to the deformations occurring at the surface of the material subject to the process of Processing, but also at the changing points of the processing route as can be seen from the (Figure 2.)

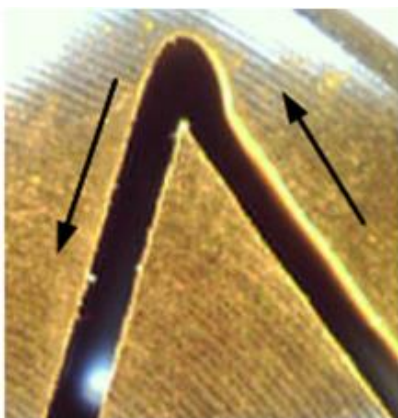

Figure 2. Working surface with abrasive water jet

2. GENERATED 3D MODEL BY COMPUTER MODELING OF THE MIXING CHAMBER

In terms of mechanical properties PLA (Polylactic Acid) have strength properties 50 MPa (Tensile Strength Ultimate (UTS) and ABS (Acrylonitrile Butadiene Styrene) material with strength properties

37 to 110 MPa (Tensile Strength Ultimate (UTS). Important in some application it is the glass transition temperature which is for ABS 100 °C [4] and 60 °C for PLA [5]. An important aspect in terms of technology is the possibility of finishing the surface by processes of surface finish by sanding or epoxy resin.

The importance of mechanical properties is essential from the point of view of resistance demand to the components that are carried out to follow the process. If so far it has been possible to follow the process only on the parts of the input and output of the energy jet, by 3d printing technology can be see the process inside the mixing chamber using a translated thread in the practical realization of the mixing chamber.

A great advantage of 3d printing process is given by the fact that a set of components can be achieved to a single component with direct effects on the positioning precision of the elements that ensure the generation of the jet, but also the very large insurance of the mixing chamber from the sealing point.

From the point of view of the generating components, the technology of the generating elements will be used by rotating the contour of the element to be obtained. This will start from the tube where the sapphire nozzle will be introduced to generate the liquid environment under pressure. This nozzle is mounted inside a metallic stainless-steel tube. This tube must be mounted in the mixing chamber cylindrical tube by heating the mixing chamber and inserting the tube inside it to obtain precise mounting of the metal tube in the plastic mixing chamber tube.

Next it is presented the way of generating this element from the initial phases and reaching its final form. The first element that will be generated is the plastic tube in which the metal tube will be fitted with the sapphire nozzle mounted. The diameter of the nozzle is 0.25 mm (Figure 3).

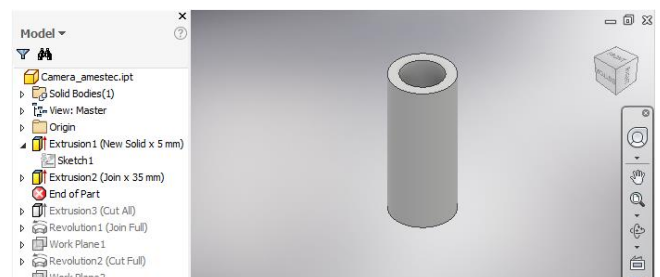

Figure 3. Tube for water jet part form plastic [3]

Next, the body of the mixing chamber can be noticed that it has a complex shape to ensure both the introduction of the abrasive inside the chamber

with a good repartition, but also of the water jet in it, and to ensure the smoother mixing of the abrasive with water under pressure (Figure 4).

Next, we will generate a circular channel on the periphery of the first cone to allow the distribution of the abrasive environment on the periphery of the water jet after a circular surface as high as possible and the completion of the inlet with abrasive medium inside mixing chamber (Figure 5).

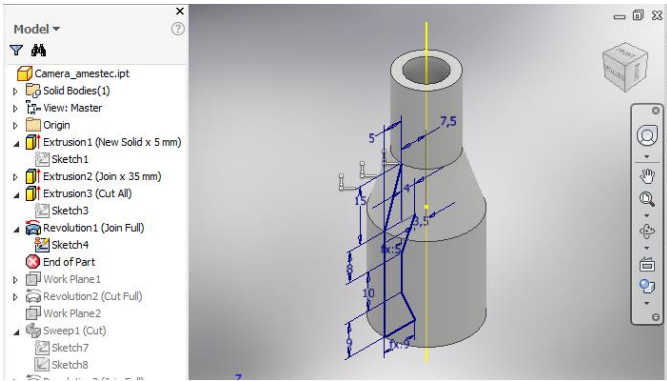

Figure 4. Mixing chamber for abrasive water jet made form plastic [3]

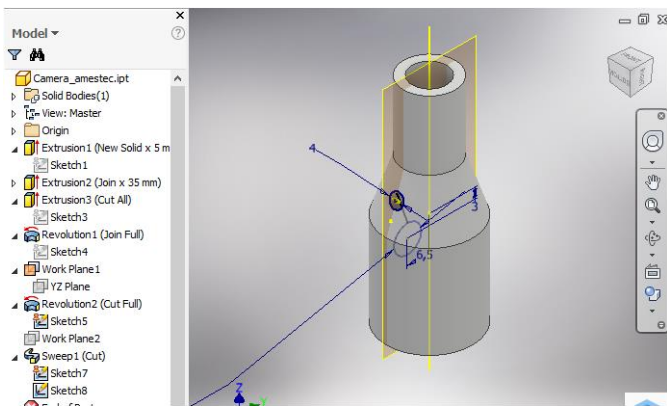

Figure 5. Alimentation with abrasive of the mixing chamber core made form plastic [3]

From those presented so far you can see both the complexity of the mixing chamber but also the fact that to achieve these through conventional procedures are needed more technological processing resources that will result in a high cost of it.

Last constructive part on the abrasive jet generation side is the tube for mounting the jet-targeting nozzle. This tube will be made of metallic material and will allow a better position of the jet on the processing surface (Figure 6).

An important element for the introduction of the abrasive is the layout of the abrasive supply holes with abrasive medium. For the initial phase three holes were designed at 120 degrees on the conical surface that penetrate to the circular ring level in the mixing chamber.

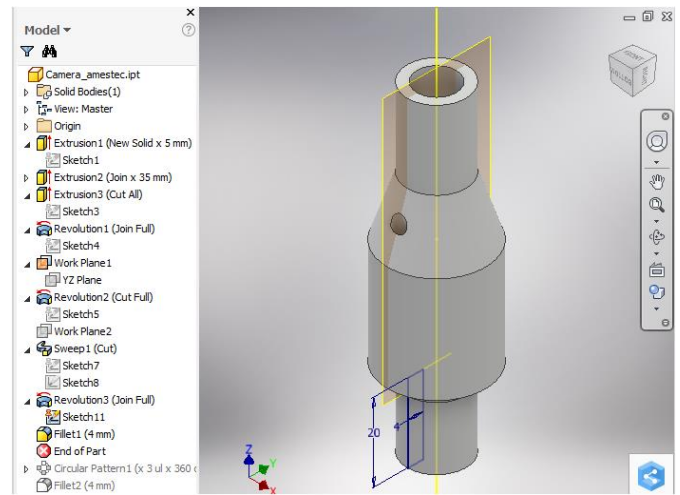

Figure 6. Tube for mounting the focusing nozzle for the abrasive jet made form plastic [3]

Making them is done using the circular generation command of a previously geometric element (Figure 7).

The supply of the holes with abrasive medium shall be carried out by means of a circular channel whose diameter is equal to the sum of the diameters of the supply holes ordered on the periphery of the conical area. Its geometrical realization is also based on the method of generation by rotation using a vertical generation plan (Figure 8).

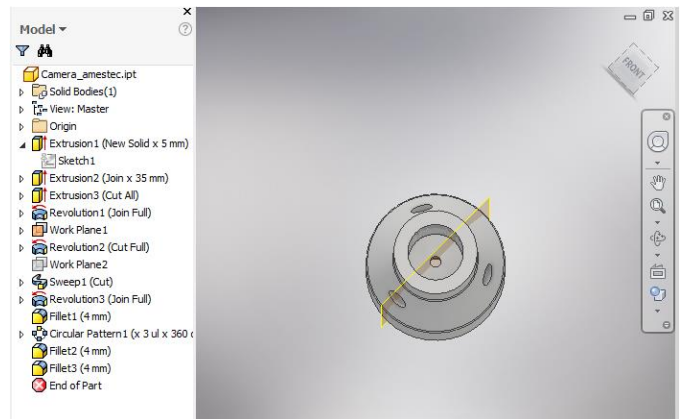

Figure 7. Alimentation orifices for mixing chamber core made form plastic [3]

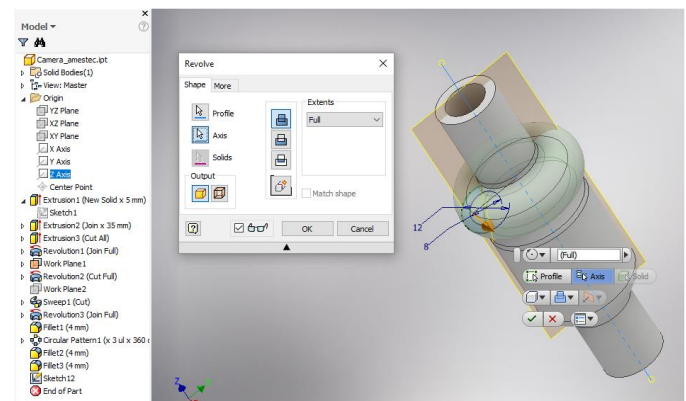

Figure 8. Channel for alimentation of the orifices for mixing chamber core made form plastic [3]

Finally, we will achieve the abrasive supply hole that will be tilted at a 15-degree angle to the liquid medium supply tube to ease the supply of abrasive medium and reduce speed losses. It should be shown that the abrasive medium will be suspended in air at a pressure of less 10 bars (Figure 9).

The last part of the mixing chamber generation process is that of the fixing of the two metallic parts and the vertical orientation and positioning of the head. From the functional point of view the machining head can rotate with 45° in the two vertical planes containing the axis of symmetry of the head and may carry a translation movement after the axial direction of the symmetry axis of the head.

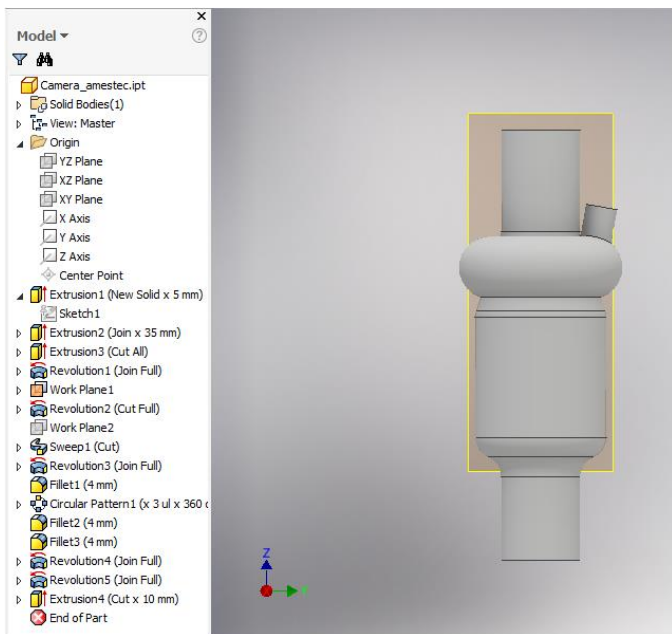

Figure 9. Orifice for alimentation of the orifices for mixing chamber core made form plastic [3]

The way this complex component is made will be the subject of another experimental process (Figure 10).

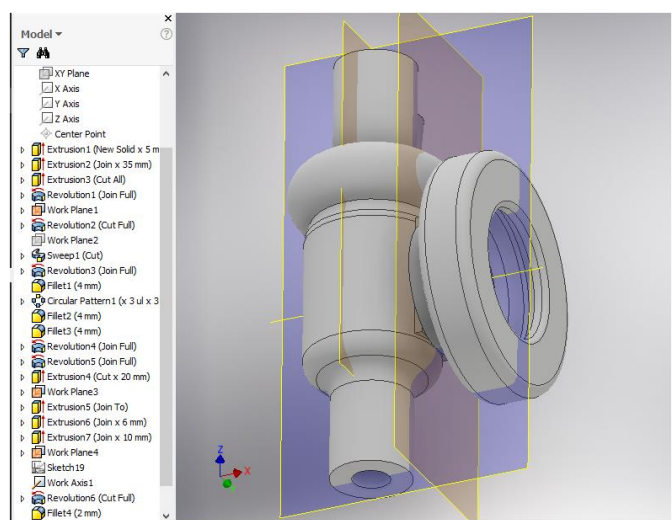

Figure 10. Fixing part and orientation part for mixing chamber core made form plastic [3]

For the completion of the spins on the inner ring, there is a route of 3 mm diameter bearing balls and a cylindrical gear crown with inclined teeth that will engage with a pinion mounted on a step-by-step motor of 1.8 degrees on the angle of rotation. This constructive solution provides precision to the processing head 200 steps per rotation and with a ratio of 1 to 5, 20 pinion teeth and 100 crown teeth will be obtained at a full rotation 1.000 steps per rotation so 0.36 degrees per step of command. If we power the motor in the half-step command it will reach 0.18 degrees per step which will allow us to achieve a very high precision of rotation.

3. 3D GENERATED AND TECHNOLOGY OF GENERATION OF THE PARTS

The process of generating of the mixing chamber is based on the 3d printing type Cura for generated the layer.

For generation in view of the structure and functional role of the mixing chamber, the vertical orientation position with support (Figure 11).

From the point of view of positioning it is important both for the mode of layout of the layers in the generation process, but also from the point of view of the processing period. From the first point of view as could be seen from [6] surface roughness is lower on the vertical orientation than roughness on the horizontal surface orientation.

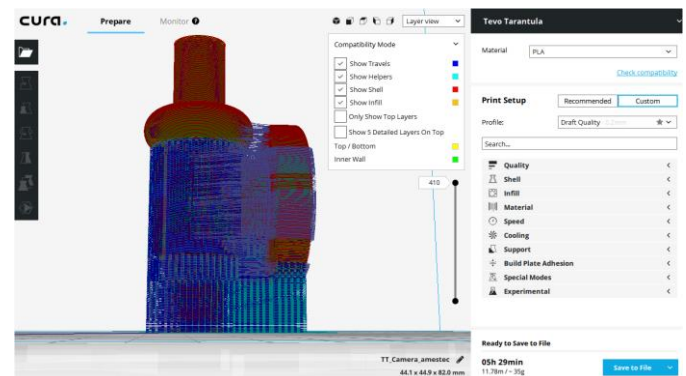

Figure 11. Vertical positioning for mixing chamber core made form plastic [7]

From the point of view of the processing time and the consumption of material for generation, under the conditions of maintaining the identical processing parameters we have for the vertical position time data in (Figure 12) time 5 hours 32 minutes and 11,72 m and for the horizontal position the data from (Figure 13) time 5 hours 5 minutes and 12,32 m files.

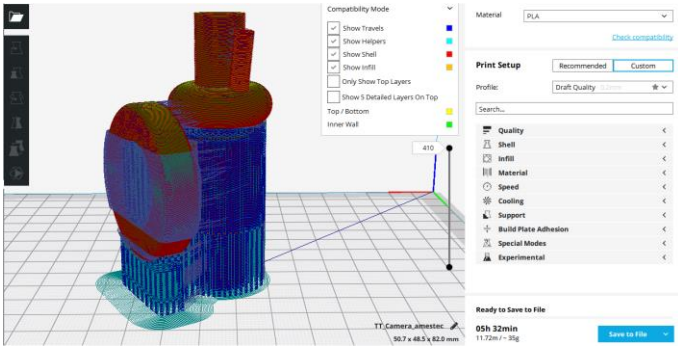

Figure 12. Vertical processing 3D printed for mixing chamber core made form plastic [7]

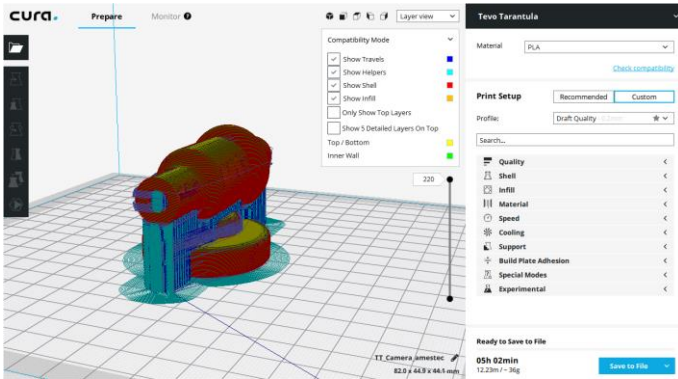

Figure 13. Horizontal processing 3D printed for mixing chamber core made form plastic [7]

The conclusion is evident, longer time for vertical solution, less material for vertical solution and better quality of the surface for the vertical solution.

4. GENERATE THE MIXING CHAMBER FOR ABRASIVE WATERJET WITH 3D PRINTING

The generation program is a relatively complex one that is based on the tracing of the graphical elements made in each of the generation plans.

From the generation point of view the program is structured three parts as can be seen from the structure of a program made in code G. The first part is the starting part of the program with the generating command for processing and verification of the state of the variables that ensure a good process. The second part is that of the program itself, and the last one is the finish of the process of generation and withdrawal of the processing head in a origin chosen or determined from or by the generation system.

It can be observed in (Figure 14) that the number of screens is 416 for the vertical version of which 24 for the starting part of the program, the central part from 25 to 482957 and the final (Figure 15) has the last lines of code to stop the generation process.

```

1 ;FLAVOR:RepRap
2 ;TIME:19956
3 ;Filament used: 11.7195m
4 ;Layer height: 0.2
5 ;Generated with Cura_SteamEngine 3.2.1
6 T0
7 M190 S60
8 M104 S200
9 M109 S200
10 M82 ;absolute extrusion mode
11 G21 ;metric values
12 G90 ;absolute positioning
13 M82 ;set extruder to absolute mode
14 M107 ;start with the fan off
15 G28 X0 Y0 ;move X/Y to min endstops
16 G28 Z0 ;move Z to min endstops
17 G1 Z15.0 F9000 ;move the platform down 15mm
18 G92 E0 ;zero the extruded length
19 G1 F200 E3 ;extrude 3mm of feed stock
20 G92 E0 ;zero the extruded length again
21 G1 F9000
22 ;Put printing message on LCD screen
23 M117 Printing...
24 M83 ;relative extrusion mode
25 ;LAYER_COUNT:410

```

Figure 14. Starting program for processing 3D printed for mixing chamber core made form plastic [7]

```

482958 ;TIME_ELAPSED:19956.579976
482959 G1 F1600 E-4.5
482960 M82 ;absolute extrusion mode
482961 M104 S0 ;extruder heater off
482962 M140 S0 ;heated bed heater off (if you have it)
482963 G91 ;relative positioning
482964 G1 E-1 F300 ;retract the filament a bit before lifting the nozzle, to release some of the pressure
482965 G1 Z40.5 E-5 X-20 Y-20 F9000 ;move Z up a bit and retract filament even more
482966 G90 ;absolute positioning
482967 G1 X0 Y0 Z0 F9000 ;move extruder out of the way by moving the baseplate to the front for easier access to printed object
482968 M04 ;steppers off
482969 M83 ;relative extrusion mode
482970 M104 S0
482971 ;End of Gcode

```

Figure 15. Finishing program for processing 3D printed for mixing chamber core made form plastic [7]

5. FUTURE DEVELOPMENT AND PERSPECTIVES

The results obtained from this study are a beginning to demonstrate the efficiency of the energy transfer process from the water jet to the abrasive and to study the phenomena that occur during this process. Other research will be under consideration:

- performing pneumatic measurements to determining the influence of air pressure on particles entrained on the abrasive introduction side;
- determining the forces generated at the surface of the material subjected to the erosion process using the new jet generation method;
- investigation of the surfaces obtained by the abrasive water jet erosion process compared to those resulting from the traditional blending process;
- studying the energy efficiency of the water mixture with the abrasive medium through the new process compared to the traditional process;
- determining the technological parameters of the mixture to optimize the process of water jet processing with abrasive in suspension;
- the analysis of geometric forms of equal resistance and their methods of realization to increase the efficiency of the process of mixing water with abrasive medium.

6. CONCLUSION

Important conclusions on this study are merit to mentioning:

- technological 3D printing process it is a simple and cheap method to product of parts for abrasive water jet installation;
- as presented in the paper, the purpose of this research is to establish the frame of realization of the mixing chamber, the method of generating it and the actual realization of a mixing chamber by 3D printing on the geometry designed for the validation of the generation model;
- the determination of the technological parameters of the blending chamber and the study by optical visualization methods was followed both during the 3D printing process and after generating the constructive element considered;
- the behaviour of the material used for 3D printing in contact with fibrous or metallic materials that were introduced during the printing process in the generated object;
- some parts of the mixing chamber are subjected to mechanical cavitation or hydrodynamic stresses because they have been made with different material densities to increase their resistance to the above-mentioned demands.

7. ACKNOWLEDGEMENTS

It should be noted that this study was conducted on their own author and not part of any research program funded from national or international financial fund.

8. REFERENCES

1. Nannan G and Ming C L 2013 Additive manufacturing: technology, applications and

- research needs *Front. Mech. Eng.* 8(3): (Higher Education Press and Springer-Verlag Berlin Heidelberg) pp 215-43, access (2018)
2. *** -Inventor student 2017, access (2017)
3. Libor Sitek, Josef Foldyna, Petr Martinec, Jiří Klich, Miroslav Mašláň - ON THE PREPARATION OF PRECURSORS AND CARRIERS OF NANOPARTICLES BY WATER JET TECHNOLOGY, *Tehnički vjesnik* 19, 3(2012), 465-474, <https://www.researchgate.net/publication/288607496> On the preparation of precursors and carriers of nanoparticles by water Jet technology, access (2018)
4. *** - <http://filamentguide.net/>, access 2018
5. *** - <https://www.makeitfrom.com/material-properties/Polylactic-Acid-PLA-Polylactide>, access 2018.
6. Mircea Dorin Vasilescu, Ioan Vasile Groza - INFLUENCE OF TECHNOLOGICAL PARAMETERS ON THE ROUGHNESS AND DIMENSION OF FLAT PARTS GENERATED BY FDM 3D PRINTING, *Nonconventional Technologies Review*, Romania, September 2017, access 2018.
7. *** - <https://ultimaker.com/en/products/ultimaker-cura-software>, access (2018)
8. *** - <https://shyuanhong.en.made-in-china.com/productimage/evEJMInoJrYX-2f1j00UEqfRmQtBioT/China-Waterjet-Cutting-Head-Mixing-Chamber-for-Abrasive-Cutting-Head-Yh-009940-1-2.html>, access (2018)